

2011 KCDA CATALOG

ABRASIVES / EMERY CLOTH

Emery Cloth

9"x11" sheets, for metal surfaces. For very light metal sanding. Primarily a polishing agent but is also used for removing rust and corrosion from metal surfaces. Will produce a high polish on most metal surfaces. Qualifying Standard: Norton.

KCDA No.	Description	U/M	1-11	12+
87708	Fine Grade	50/Pkg	21.42	20.92
87709	Medium Grade	50/Pkg	21.42	20.92
87710	Coarse Grade	50/Pkg	22.76	22.22

ABRASIVES / FLINT PAPER

Flint Paper

9"x10" sheets, closed coat, for paint removal and soft wood preparation. For numerous light hand sanding jobs on wood surfaces. Flint mineral lacks hardness and toughness. Production paper is recommended for easier, faster sanding. Qualifying Standard: Norton.

KCDA No.	Type	U/M	1-11	12+
87711	Fine	100/Pkg	22.31	21.79
87712	Medium	100/Pkg	26.77	26.15
87713	Coarse	50/Pkg	18.68	18.24

ABRASIVES / RUBBING COMPOUNDS

A) Finishing Compound

White, 14 ounce bar. Qualifying Standard: Dico.

KCDA No.	U/M	1-23	24+
87770	1/Bar	21.76	21.42

B) Jewelers Rouge

Red, 2-1/2 pounds.

KCDA No.	U/M	1-23	24+
87771	1/Bar	5.49	5.41

ABRASIVES / SANDING BELTS

C) Sanding Belts

Aluminum oxide. Qualifying Standard: Norton.

KCDA No.	Size	Grit	U/M	1-5	6+
Closed Coat					
87715	6" x 48"	40	10/Slv	41.04	40.08
87716	6" x 48"	60	10/Slv	38.82	37.91
87717	6" x 48"	80	10/Slv	37.55	36.67
Open Coat					
87733	3" x 18"	100	10/Slv	16.58	16.18
87723	3" x 24"	100	10/Slv	13.39	13.07
87724	3" x 24"	120	10/Slv	13.39	13.07
87725	3" x 24"	150	10/Slv	15.30	14.94
87718	3" x 24"	36	10/Slv	17.21	16.81
87728	4" x 24"	40	10/Slv	22.31	21.79
87731	3" x 18"	60	10/Slv	16.58	16.18
87721	3" x 24"	60	10/Slv	14.02	13.69
87732	3" x 18"	80	10/Slv	13.07	12.76
87722	3" x 24"	80	10/Slv	14.02	13.69
87729	4" x 24"	80	10/Slv	20.40	19.92

ABRASIVES / SANDING CLOTH

D) Aluminum Oxide Cloth

1-1/2" x 50 yards. Qualifying Standard: Norton, ARC.

KCDA No.	Grit	U/M	1-11	12+
87705	40	1/Roll	13.25	12.94
87704	50	1/Roll	12.98	12.67
87702	80	1/Roll	12.61	12.31
87701	100	1/Roll	12.61	12.31
87700	120	1/Roll	12.61	12.31

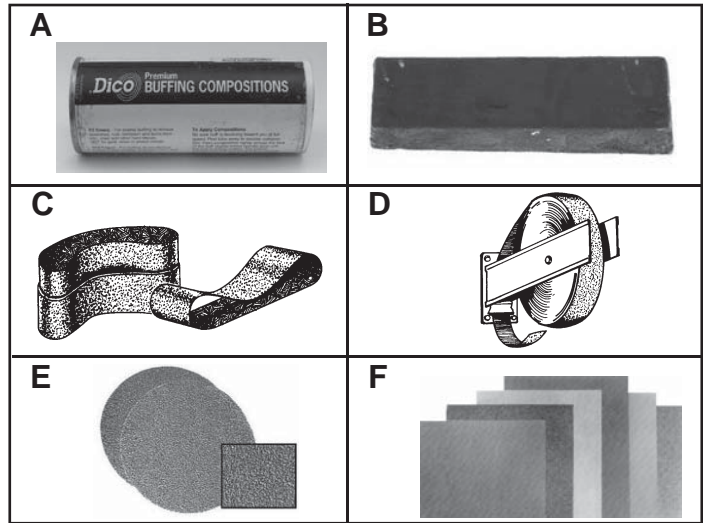

ABRASIVES / SANDING DISCS

E) Sanding Discs

Aluminum oxide, cloth back, no hole, pressure sensitive adhesive backing, resin bond. Qualifying Standard: Norton.

KCDA No.	Size	Grit	U/M	1-11	12+
87736	12"	36	25/Pkg	102.00	99.60
87737	12"	60	25/Pkg	85.43	83.42
87735	12"	100	25/Pkg	85.43	83.42
87741	16"	60	25/Pkg	86.06	84.04

Sanding Discs

Aluminum oxide, fiber back, open coat. 7/8" hole. Qualifying Standard: Qualifying Standard: Norton.

KCDA No.	Size	Grit	U/M	1-11	12+
87739	7"	60	25/Pkg	21.08	20.58

ABRASIVES / SANDPAPER / ALUMINUM OXIDE

Aluminum Oxide Sandpaper

Open coat, 4-1/2" x 11" sheets, for orbital sander. Qualifying Standard: Carborundum.

KCDA No.	Type	Grit	U/M	1-23	24+
87757	Extra Fine	220	100/Pkg	15.94	15.56
87756	Fine	120	100/Pkg	15.94	15.56
87755	Medium	80	100/Pkg	19.76	19.30
87754	Coarse	50	100/Pkg	25.50	24.90

F) Aluminum Oxide Sandpaper

Open coat, 9" x 11". For use with various oscillating machines on both wood and metal surfaces for professional results. Open coated with hard, tough aluminum oxide material.

KCDA No.	Grit	U/M	1-23	24+
88833	80	50/Slv	18.30	17.87
88834	100	100/Slv	25.50	24.90
88835	120	100/Slv	28.69	28.01
88836	180	100/Slv	24.10	23.53
88837	220	100/Slv	24.10	23.53

ABRASIVES / SANDPAPER / GARNET

Garnet Cabinet Sandpaper

4-1/2" x 11" sheets, open coat. Qualifying Standard: Carborundum.

KCDA No.	Grit	U/M	1-49	50+
82878	D/60	12/Pkg	11.65	11.48
82877	D/80	12/Pkg	11.65	11.48
82876	C/120	12/Pkg	11.65	11.48

2011 KCDA CATALOG

Garnet Cabinet Sandpaper

9" x 11", open coat, "D" backing. For reconditioning wood surfaces before finishing. Recommended for removal of varnish, paint and lacquer. Sands to smooth finish. Open coat mineral coating. Qualifying Standard: Norton.

KCDA No.	Grit	U/M	1-23	24+
87748	40	50/Pkg	31.88	31.13
87749	80	50/Pkg	19.25	18.80

Garnet Finish Sandpaper

9" x 11", open coat, "A" backing. Qualifying Standard: Norton.

KCDA No.	Grit	U/M	1-23	24+
87750	100	100/Pkg	25.82	25.21
87751	120	100/Pkg	25.82	25.21
87752	150	100/Pkg	25.82	25.21
87753	220	100/Pkg	25.50	24.90

ABRASIVES / SANDPAPER / SILICON CARBIDE

A) Silicon Carbide Paper

9" x 11", "A" backing, wet or dry closed coat. Qualifying Standard: Alco.

KCDA No.	Grit	U/M	1-23	24+
87759	80	50/Pkg	29.64	28.95
87760	120	50/Pkg	19.81	19.35
87761	180	50/Pkg	14.04	13.71
87762	220	50/Pkg	14.04	13.71
87765	320	50/Pkg	14.04	13.71
87763	400	50/Pkg	14.04	13.71
87764	600	50/Pkg	14.04	13.71

ABRASIVES / STEEL WOOL

B) Steel Wool Pads

4-1/2"x4-1/2"x1". 16 pads per package. Qualifying Standard: Rhodes.

KCDA No.	Description	U/M	1-23	24+
34615	#00 Extra Fine	6/Case	18.06	17.64
34616	#0 Fine	6/Case	18.06	17.64
34617	#1 Standard	6/Case	18.06	17.64
34618	#2 Medium	6/Case	18.06	17.64

ABRASIVES / STONES & SHARPENERS

C) Chisel and Plane Sharpener

Keeps blades razor sharp and to original bevel and angle. Spring blade clamp will take blades up to 2-1/2" wide. Roller screw can be adjusted to the correct blade bevel. For using with oil stone. Qualifying Standard: General.

KCDA No.	U/M	1-17	18+
87487	Ea	22.04	21.53

D) Round End Slip Stones

Round edge slips are ideal for precision sharpening and honing of bead planers, curved knives, molders knives and wood gouges.

KCDA No.	Size	U/M	1-23	24+
87528	Medium, 4"x1"x7/16"x3/16"	Ea	8.59	8.45

Sharpening Stones

Combination, fine and coarse. Qualifying Standard: Carborundum.

KCDA No.	Description	U/M	1-23	24+
87526	Round, 4" x 1", #107	Ea	20.82	20.33
87527	Rectangular, 6" x 2" x 1", #109	Ea	18.60	18.16

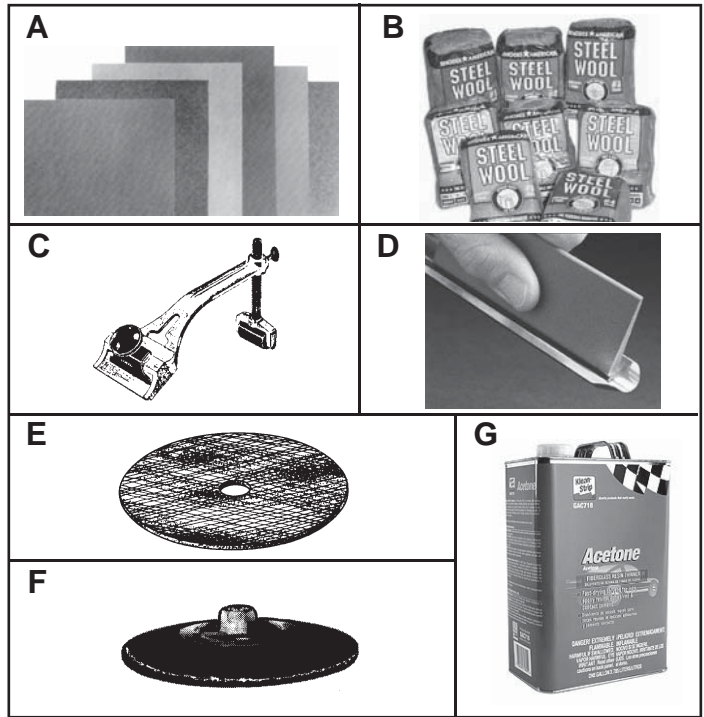

ABRASIVES / WHEELS / CUTOFF

E) Cutoff Wheels

Resinoid bond, reinforced, type 1, aluminum oxide. For abrasive cutoff saws. Use on steel only. Qualifying Standard: Tailin.

KCDA No.	Size	U/M	1-5	6+
87096	1/8" x 12" x 1"	10/Box	49.41	48.62

ABRASIVES / WHEELS / GRINDING

F) Disk Wheel

24 Grit aluminum oxide, raised 11 hub with throwaway adapter, resinoid bond, reinforced, type 27, for weld grinding, and fast stock removal. Qualifying Standard: Continental.

KCDA No.	Size	U/M	1-49	50+
87069	7" x 1/4" x 5/8"	Ea	4.90	4.71

Grinding Wheel

24 grit, 4"x 1/4" x 5/8", aluminum oxide, vitrified bond, bench pedestal grinding. Qualifying Standard: Norton.

KCDA No.	U/M	1-7	8+
87071	10/Box	19.04	18.74

Grinding Wheels

6"x 1", aluminum oxide, vitrified bond, bench-pedestal grinding, type 1. Qualifying Standard: CGW.

KCDA No.	Description	U/M	1-23	24+
87084	36 vitr, 5/8" arbor	Ea	10.71	10.46
87082	60 vitr, 5/8" arbor	Ea	10.71	10.46

ACETONE

G) Acetone Solvent

Qualifying Standard: Klean-Strip.

KCDA No.	U/M	1-23	24+
88054	Gal	22.36	22.02
KCDA No.	U/M	1-11	12+
88055	5 Gal/Can	95.11	92.88

Please check our website at www.kcda.org - Click on ordering and Supply Link for the most current listing of products and pricing. Pricing in this catalog are as of the printing date and are subject to change without notice.



2011 KCDA CATALOG

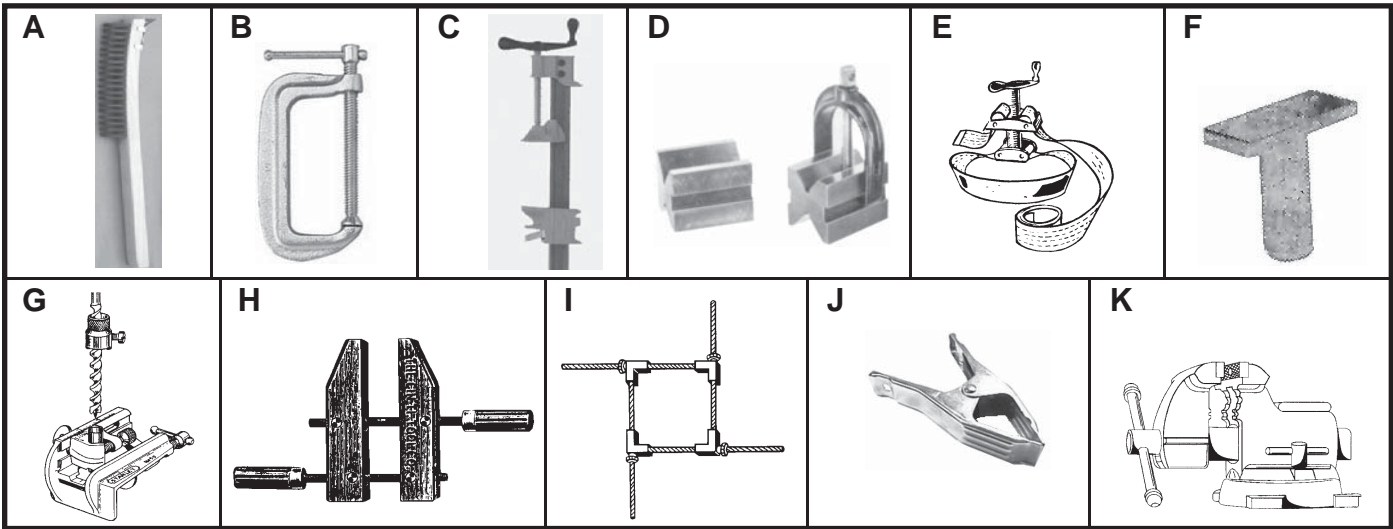

BRUSH, SCRATCH SCRAPE

A) Scratch-Scrape Brush

Three rows wire bristle in 12" wood handle, 6" grip, scraper on end. Qualifying Standard: Linzer.

KCDA No.	U/M	1-47	48+
86485	Ea	1.41	1.39

CEMENT ADHESIVE

Sanding Disc Cement

For holding discs to back up pad, 5 ounces. Qualifying Standard: 3M.

KCDA No.	U/M	1-47	48+
87744	1/Tube	6.67	6.41

CLAMPING TOOLS / "C" CLAMPS

B) C Clamps

Qualifying Standard: Jorgensen.

KCDA No.	Throat	Opening	U/M	1-23	24+
86580	1-7/8"	3"	Ea	8.59	8.39
86581	2-1/8"	4"	Ea	10.81	10.56
86582	2-3/4"	6"	Ea	16.15	15.77
KCDA No.	Throat	Opening	U/M	1-11	12+
86583	3-1/4"	8"	Ea	23.06	22.52
86584	3-5/8"	10"	Ea	32.69	31.92

CLAMPING TOOLS / "I" BAR CLAMPS

C) I Bar Clamps

With metal handle. Qualifying Standard: Hargrave, Jorgensen.

KCDA No.	Size	U/M	1-11	12+
86570	2	Ea	30.09	29.38
86571	3	Ea	32.26	31.50
86572	4	Ea	35.55	34.71
86573	6	Ea	42.78	41.77

CLAMPING TOOLS / "V" CLAMPS

D) V Clamp

With blocks. Qualifying Standard: General.

KCDA No.	U/M	1-11	12+
86640	2/Set	36.34	35.48

CLAMPING TOOLS / BAND

E) Band Clamp

2" x 10", canvas, screw adjustable. Qualifying Standard: Jorgensen.

KCDA No.	U/M	1-5	6+
86560	Ea	69.49	67.85

CLAMPING TOOLS / BENCH STOP

F) Woodworking Bench Stop

1/4" x 1" x 2-1/4", 3/4" x 2". Qualifying Standard: Jorgensen.

KCDA No.	U/M	1-47	48+
86060	Ea	3.87	3.81

CLAMPING TOOLS / DOWLING JIG

G) Doweling Jig

2-7/8" capacity with set of six guides. Qualifying Standard: General.

KCDA No.	U/M	1-11	12+
87190	Ea	37.36	36.48

CLAMPING TOOLS / HANDSCREW CLAMPS

H) Handscrew Clamps

Qualifying Standard: Jorgensen.

KCDA No.	Opening	Size	U/M	1-11	12+
86610	2"	4"	Ea	12.10	11.82
86611	3"	6"	Ea	13.97	13.65
86612	4-1/2"	8"	Ea	16.72	16.32
86613	6"	10"	Ea	19.13	18.67
86614	8-1/2"	12"	Ea	21.94	21.43

CLAMPING TOOLS / MITRE & CORNER CLAMP

I) Mitre and Corner Clamp

Four corner, 2" to 24". Qualifying Standard: Jorgensen.

KCDA No.	U/M	1-11	12+
86630	Ea	13.41	13.10

CLAMPING TOOLS / SPRING CLAMPS

J) Spring Clamps

Qualifying Standard: Jorgensen.

KCDA No.	Size	U/M	1-35	36+
86600	1"	Ea	1.14	1.12
86601	2"	Ea	2.11	2.08
86602	3"	Ea	5.66	5.57

CLAMPING TOOLS / VISE

K) Machinists Vise

Stationary base, jaw width: 4-1/2", throat depth: 4-1/2", 6" opening, manual screw. Qualifying Standard: Weller.

KCDA No.	U/M	1-5	6+
87552	Ea	147.91	145.53

2011 KCDA CATALOG

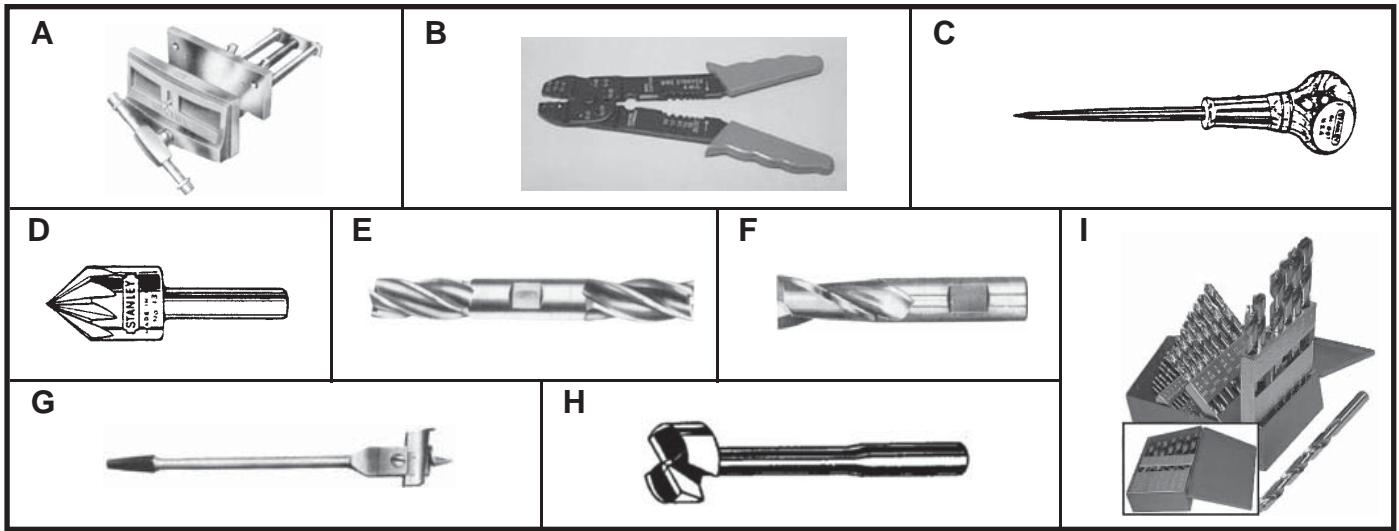

A) Woodworkers Vise

Jaw size: 4" x 10", 12" opening, continuous screw, metal handle, all steel dog. Qualifying Standard: Wilton.

KCDA No.	U/M	1-5	6+
87556	Ea	186.03	183.04

CRIMPING TOOLS

B) Crimping Tool

Steel, vinyl covered handles. Qualifying Standard: Nasco.

KCDA No.	U/M	1-29	30+
03532	Ea	1.55	1.53

CUTTING TOOLS / AWL

C) Scratch Awl

6". Qualifying Standard: General.

KCDA No.	U/M	1-23	24+
86040	Ea	4.88	4.81

CUTTING TOOLS / BITS / COUNTERSINK

Drill/Countersink Bits

Metal. Qualifying Standard: Republic Drill.

KCDA No.	Description	U/M	1-35	36+
88791	1/8" Drill, 5/16" Body, #4	Ea	1.06	1.05
88792	3/16" Drill, 7/16" Body, #5	Ea	2.29	2.26

Multiflute Countersink Bits

High speed steel, 3 flutes, for counter sinking most material: ferrous, nonferrous, nonmetallic. Qualifying Standard: Republic Drill.

KCDA No.	Description	U/M	1-35	36+
88782	1/4"D, 1/4"S.D., 60 Deg.	Ea	4.01	3.95
88788	1/4"D, 1/4"S.D., 100 Deg.	Ea	4.01	3.95
88783	3/8"D, 1/4"S.D., 60 Deg.	Ea	4.69	4.62
88787	1/2"D, 1/2"S.D., 82 Deg.	Ea	5.79	5.70

D) Rose Countersink Bit

1/2" cut, 1/4" drill shank. Qualifying Standard: Rutland.

KCDA No.	U/M	1-35	36+
86660	Ea	3.91	3.85

CUTTING TOOLS / BITS / ELECTRICIANS

Electricians Bit

3/8" x 18". Qualifying Standard: Irwin.

KCDA No.	U/M	1-23	24+
86110	Ea	12.67	12.47

CUTTING TOOLS / BITS / END MILLS

E) Double End Mills

4 flute, high speed steel. Qualifying Standard: Rutland.

KCDA No.	Length		Overall		Shank	
	Dia.	Cut	Dia.	U/M	1-22	23+
86325	3/8"	3/8"	1/8"	Ea	5.48	5.35
86329	3/8"	5/8"	1/4"	Ea	5.48	5.35
86327	3/8"	1/2"	3/16"	Ea	5.48	5.35

F) Single End Mills

2 flute high speed steel. Qualifying Standard: Rutland.

KCDA No.	Lenth		Overall		Shank	
	Dia.	Cut	Dia.	U/M	1-22	23+
86294	3/8"	3/8"	3/8"x2-5/16"	Ea	3.58	3.50
86298	3/8"	9/16"	9/16"x2-5/16"	Ea	3.97	3.87

CUTTING TOOLS / BITS / EXPANSIVE

G) Expansive Bits

Qualifying Standard: Irwin.

KCDA No.	Size	U/M	1-23	24+
86131	7/8" to 3"	Ea	42.14	41.15

CUTTING TOOLS / BITS / FORSTNER

H) Forstner Bits

For machines, by 16ths. Qualifying Standard: Convalco.

KCDA No.	Dia.	Shank	Size	U/M	1-23	24+
86151	3/8"	3/8"	#6	Ea	29.04	28.36

CUTTING TOOLS / BITS / INDEX

I) Drill Index

Straight shank high speed steel in indexed case. Qualifying Standard: Morse.

KCDA No.	Description	U/M	1-4	5+
86716	1/16" to 1/2", by 64ths	1/Set	19.17	18.86
86718	Letters: A to Z	1/Set	20.88	20.54
86717	Numbers: 1 to 60	1/Set	18.49	18.19

CUTTING TOOLS / BITS / LATHE

Lathe Bits

Square. Qualifying Standard: Riggs Tool.

KCDA No.	Size	U/M	1-11	12+
88778	5/16"x2-1/2"	10/Pkg	15.30	14.94
KCDA No.	Size	U/M	1-5	6+
88779	3/8"x3"	10/Pkg	21.67	21.17

2011 KCDA CATALOG

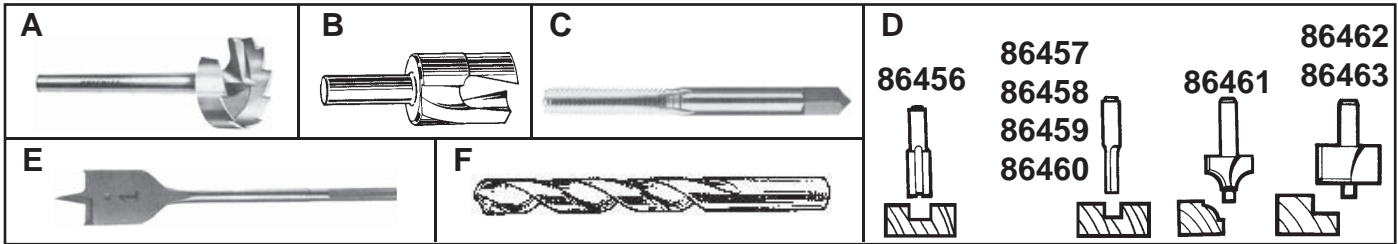

CUTTING TOOLS / BITS / MASONRY

Masonry Drill Bits

Carbide tip. Qualifying Standard: Republic.

KCDA No.	Size	U/M	1-47	48+
88670	1/4"x4"	Ea	0.89	0.88
88671	3/8"x4"	Ea	1.77	1.75
KCDA No.	Size	U/M	1-23	24+
88672	1/2"x4"	Ea	3.14	3.06

CUTTING TOOLS / BITS / MULTI-SPUR

A) Multi-Spur Bits

Qualifying Standard: Forest City.

KCDA No.	Size	U/M	1-11	12+
86185	1-1/4"	Ea	33.52	32.73
KCDA No.	Size	U/M	1-5	6+
86193	3"	Ea	135.53	132.34

CUTTING TOOLS / BITS / PLUG CUTTER

B) Plug Cutter

1/4" shank. Qualifying Standard: Stanley.

KCDA No.	Desc	U/M	1-23	24+
86686	Screw Size #6	Ea	4.08	4.02

CUTTING TOOLS / BITS / PLUG TAP

C) Plug Tap Bits

High speed steel, 4 flute. Qualifying Standard: Vermont.

KCDA No.	Size	U/M	1-47	48+
89924	1/2-20	Ea	5.10	5.02
89912	3/8-16	Ea	2.78	2.74
89911	5/16-18	Ea	2.38	2.35

Plug Tap Bits

High speed steel. Qualifying Standard: Vermont.

KCDA No.	Desc	Size	U/M	1-47	48+
89900	3 Flute	4-40	Ea	2.40	2.36
89902	4 Flute	8-32	Ea	1.86	1.84

CUTTING TOOLS / BITS / ROUTER

D) Router Bits

1/4" shank. Qualifying Standard: Vermont, Black & Decker.

KCDA No.	Size	Description	U/M	1-23	24+
86456	1/4"	Straight, High Speed Steel	Ea	4.51	4.44
86457	1/4"	Straight, Carbide Tipped	Ea	9.48	9.33
86461	1/4"	Beading, High Speed Steel	Ea	8.70	8.57
86458	1/2"	Straight, High Speed Steel	Ea	4.92	4.84
86460	3/4"	Straight, High Speed Steel	Ea	4.69	4.62
86462	3/8"	Rabbeting, High Speed Steel	Ea	9.26	9.12
86463	3/8"	Rabbeting, Carbide Tipped	Ea	19.41	19.11
86459	1/2"	Straight, Carbide Tipped	Ea	10.85	10.68

Please check our website at www.kcda.org - Click on ordering and Supply Link for the most current listing of products and pricing. Pricing in this catalog are as of the printing date and are subject to change without notice.

CUTTING TOOLS / BITS / SPEEDBORE

E) Speedbore Bits

Spade type. Qualifying Standard: Vermont.

KCDA No.	Size	U/M	1-47	48+
86210	1/4"	Ea	2.56	2.52
86212	3/8"	Ea	2.32	2.28
86214	1/2"	Ea	2.32	2.28
86215	9/16"	Ea	2.43	2.40
86216	5/8"	Ea	2.55	2.51
86217	11/16"	Ea	2.55	2.51
86218	3/4"	Ea	2.86	2.82
86219	13/16"	Ea	3.00	2.96
86220	7/8"	Ea	2.68	2.64
86221	15/16"	Ea	2.82	2.78
86222	1"	Ea	2.82	2.78
86223	1-1/8"	Ea	4.09	4.03
86224	1-1/4"	Ea	4.09	4.03
86226	1-1/2"	Ea	4.09	4.03
86225	1-3/8"	Ea	4.09	4.03

CUTTING TOOLS / BITS / TWIST DRILLS

F) Twist Drill Bits

Jobber length, fractional size, high speed steel, straight shank. Qualifying Standard: Republic Drill.

KCDA No.	Size	U/M	1-23	24+
88673	1/32"	12/Pkg	3.98	3.88
88675	1/16"	12/Pkg	3.52	3.44
88676	5/64"	12/Pkg	3.52	3.44
88677	3/32"	12/Pkg	3.98	3.88
88678	7/64"	12/Pkg	3.98	3.88
88679	1/8"	12/Pkg	3.98	3.88
88683	3/16"	12/Pkg	5.20	5.08
88680	9/64"	12/Pkg	4.74	4.63
88681	5/32"	12/Pkg	4.74	4.63
88684	13/64"	12/Pkg	6.43	6.27
88682	11/64"	12/Pkg	5.05	4.93
88685	7/32"	12/Pkg	6.73	6.57
88686	15/64"	12/Pkg	7.14	6.97
88687	1/4"	12/Pkg	7.65	7.47
88688	17/64"	12/Pkg	7.65	7.47
88691	5/16"	12/Pkg	12.09	11.80
88692	21/64"	12/Pkg	14.38	14.04
88693	11/32"	12/Pkg	16.22	15.84
88694	23/64"	12/Pkg	17.90	17.48
88695	3/8"	12/Pkg	18.21	17.78
88674	3/64"	12/Pkg	3.83	3.73
88697	13/32"	6/Pkg	10.10	9.86
88698	27/64"	6/Pkg	11.78	11.50
88699	7/16"	6/Pkg	12.16	11.88
88700	29/64"	6/Pkg	13.39	13.07
88702	31/64"	6/Pkg	13.77	13.45
88701	15/32"	6/Pkg	13.69	13.37
88689	9/32"	12/Pkg	8.57	8.37
88690	19/64"	12/Pkg	11.32	11.06
88696	25/64"	6/Pkg	9.72	9.49
88703	1/2"	6/Pkg	14.31	13.97

2011 KCDA CATALOG

Twist Drill Bits

1/2" shank, high speed. Qualifying Standard: Riggs Tool.

KCDA No.	Size	U/M	1-11	12+
88767	3/4"	Ea	5.89	5.75
KCDA No.	Size	U/M	1-5	6+
88776	1-1/4"	Ea	13.91	13.58
KCDA No.	Size	U/M	1-11	12+
88768	7/8"	Ea	7.01	6.85
88769	1"	Ea	9.21	8.99
88766	5/8"	Ea	4.87	4.76

A) Twist Drill Bits

High speed steel, straight shank gage size. Qualifying Standard: Republic Drill.

KCDA No.	Size	U/M	1-11	12+
88759	#5	12/Pkg	9.64	9.41
88757	#7	12/pkg	8.57	8.37
88749	#15	12/Pkg	7.65	7.47
88709	#55	12/Pkg	4.44	4.33
88705	#59	12/Pkg	4.44	4.33

Twist Drill Bits

Economy, high speed steel, straight shank, jobber length, fractional size. Qualifying Standard: Morse.

KCDA No.	Size	U/M	1-23	24+
86353	5/64"	12/Pkg	3.67	3.59

CUTTING TOOLS / BLADES / BANDSAW

Bandsaw Blades

3/8" wide x 96" long, 'bimetal construction, 4 hook tooth, for Powermatic 141, .025 thick, high speed steel. Qualifying Standard: Simonds.

KCDA No.	U/M	1-11	12+
89970	Ea	31.74	31.23

Bandsaw Blades

93-1/2" long, .025 thick, high speed steel, hook tooth. Bimetal construction. Qualifying Standard: MK Morse.

KCDA No.	Width	Teeth	U/M	1-11	12+
89956	1/4"	6	Ea	8.85	8.71
89957	3/8"	4	Ea	9.18	9.03

B) Bandsaw Blades

Skip tooth, for 14" delta, .025 thick, high speed steel. Qualifying Standard: MK Morse.

KCDA No.	Size	Teeth	U/M	1-23	24+
87345	3/8" W x 93-1/2" L	4	Ea	9.40	9.18
87343	1/2" W x 93-1/2" L	4	Ea	9.77	9.54
87344	3/4" W x 93-1/2" L	4	Ea	11.45	11.18
87341	1/4" W x 93-1/2" L	6	Ea	9.07	8.85
87342	3/8" W x 93-1/2" L	6	Ea	9.58	9.35

Bandsaw Blades

Skip tooth, for 20" delta, .025 thick, high speed steel. Qualifying Standard: Simonds.

KCDA No.	Size	Teeth	U/M	1-23	24+
87350	1/4" W x 141" L	6	Ea	10.91	10.66
87351	3/8" W x 141" L	4	Ea	11.67	11.39

Bandsaw Blades

Skip tooth, for new style Rockwell Delta, .025 thick, hi-speed steel. Qualifying Standard: Simonds.

KCDA No.	Size	Teeth	U/M	1-23	24+
87355	1/4" W x 150" L	6	Ea	11.14	10.88
87356	3/8" W x 150" L	4	Ea	11.92	11.64
87358	3/4" W x 150" L	3	Ea	14.85	14.50
87357	1/2" W x 150" L	4	Ea	12.52	12.23

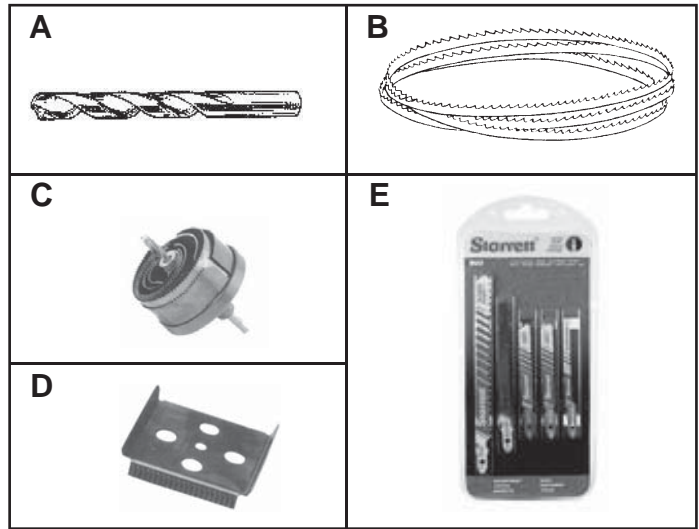

Bandsaw Blades

Skip tooth, for Powermatic 141, .025 thick, high speed steel. Qualifying Standard: Simonds.

KCDA No.	Size	Teeth	U/M	1-23	24+
87366	3/8" W x 96" L	4	Ea	9.41	9.19
87365	1/4" W x 96" L	6	Ea	9.13	8.91
87367	1/2" W x 96" L	4	Ea	9.78	9.55

CUTTING TOOLS / BLADES / COPING SAW

Coping Saw Blades

.020x.110, pin end, 6-1/2". Qualifying Standard: Olson.

KCDA No.	Teeth	U/M	1-11	12+
87407	10	80/Box	19.60	19.14
87402	15	80/Box	19.60	19.14

CUTTING TOOLS / BLADES / HACKSAW

Hacksaw Blades

High speed, .025x1/2", hard edge. Qualifying Standard: Simonds.

KCDA No.	Size	Teeth	U/M	1-11	12+
87416	10"	18	10/Slv	8.80	8.59
87417	10"	24	10/Slv	7.52	7.35
87415	12"	14	10/Slv	9.44	9.21

CUTTING TOOLS / BLADES / HOLE SAW

C) Hole Saw Set

Includes seven blades 1" to 2-1/2", 1/4" shank. Qualifying Standard: Arco.

KCDA No.	U/M	1-11	12+
87439	Ea	7.71	7.53

CUTTING TOOLS / BLADES / HOOK SCRAPER

D) Hook Scraper Blade

2-1/2. Fits hook scraper KCDA No. 87452. Qualifying Standard: Red Devil.

KCDA No.	U/M	1-23	24+
87453	1/Card	2.86	2.79

CUTTING TOOLS / BLADES / JIG SAW

E) Jig Saw Blades

5 assorted sizes: 4" wood with 6 teeth, 3" wood with 10 teeth, 2" metal with 14 teeth, 2" metal with 24 teeth, 2" metal with 32 teeth. Qualifying Standard: Starrett.

KCDA No.	U/M	1-23	24+
87437	5/Pkg	4.08	3.98

2011 KCDA CATALOG

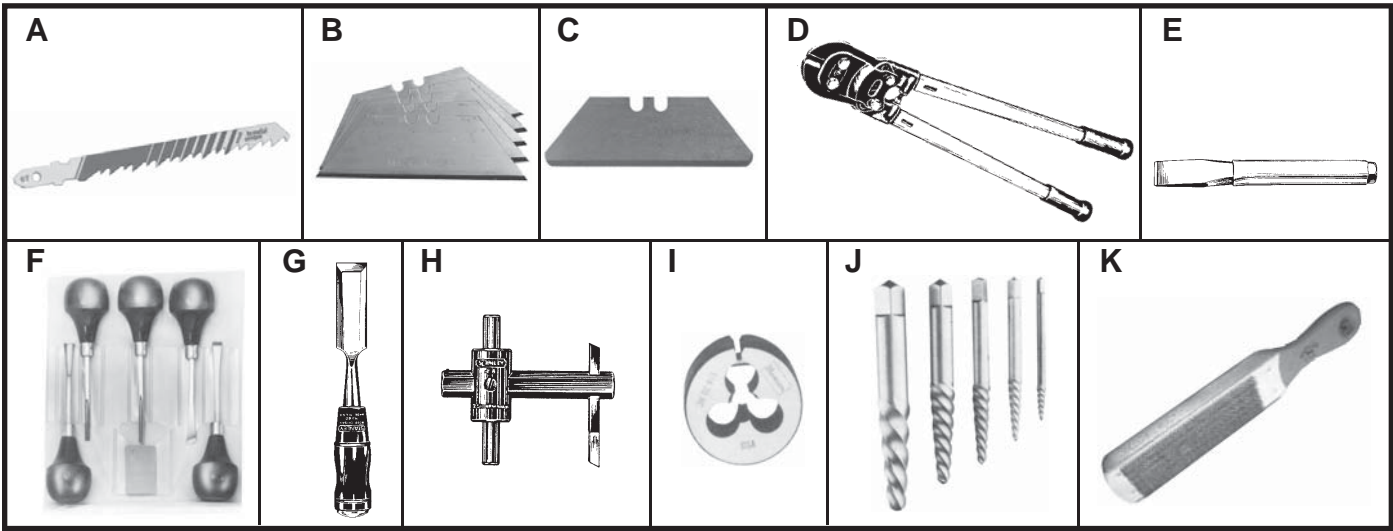

A) Jig Saw Blades

1/4" shank. Qualifying Standard: Starrett.

KCDA No.	Description	U/M	1-23	24+
87445	Wood, Medium, 10 Teeth/Inch	5/Card	8.50	8.30
87438	3", Wood, Coarse, 6 Teeth/Inch	5/Card	8.36	8.17

CUTTING TOOLS / BLADES / SCROLL SAW

Scroll Saw Blades

Power, 6", .020x.110 thick. Qualifying Standard: Olson.

KCDA No.	Teeth/Inch	U/M	1-11	12+
87389	15	144/Box	38.56	37.65
87390	10	144/Box	32.44	31.67

CUTTING TOOLS / BLADES / UTILITY KNIFE

B) Utility Knife Blades

Heavy duty, 2-7/16 x .025. Fits KCDA Nos. 87226 and 87227. Qualifying Standard: Wilmar.

KCDA No.	U/M	1-35	36+
87229	5/Pkg	0.78	0.76

C) Utility Knife Blades, Safety

Rounded edge reduces risk of accidental cuts. Helps prevent damage to carton contents when opening boxes. Fits KCDA Nos. 87226 and 87227. Qualifying Standard: Stanley.

KCDA No.	U/M	1-9	10+
87223	100/Pkg	12.29	12.10

CUTTING TOOLS / BOLT CUTTER

D) Bolt Cutters

18", 3/8 cap. Qualifying Standard: Wilmar BC18.

KCDA No.	U/M	1-5	6+
86670	Ea	19.76	19.30

CUTTING TOOLS / CHISELS

E) Cold Chisels

Qualifying Standard: Mayhew.

KCDA No.	Size	U/M	1-35	36+
86530	1/4" x 4-7/8"	Ea	1.86	1.84
86531	3/8" x 5-3/8"	Ea	2.75	2.70
86532	1/2" x 6"	Ea	2.87	2.83

F) Wood Chisel Set

Chisel carving set. Qualifying Standard: General.

KCDA No.	U/M	1-11	12+
86525	5/Set	43.90	42.87

G) Wood Chisels

3" long blade, impact resistant steel cap handle. Qualifying Standard: Great Neck.

KCDA No.	Size	U/M	1-23	24+
86540	1/4"	Ea	7.80	7.62
86541	3/8"	Ea	7.80	7.62
86544	3/4"	Ea	8.35	8.15
86543	5/8"	Ea	8.35	8.15
86542	1/2"	Ea	8.19	7.99
86545	1"	Ea	8.61	8.40
86547	1-1/2"	Ea	10.86	10.61

CUTTING TOOLS / CIRCLE CUTTERS

H) Circle Cutters

For sheet metal, mild steel, hard board, wood. Maximum 250 rpm. 1/2" shank cuts a 1-3/4" to 8-3/8" diameter and 3/8" shank cuts a 1-1/8" to 4-7/8" diameter. Qualifying Standard: General.

KCDA No.	U/M	1-23	24+
86675	Ea	17.08	16.68
86676	Ea	25.60	25.00

CUTTING TOOLS / DIES

I) Adjustable Dies

Round split, high speed steel.

KCDA No.	Size	O.D.	U/M	1-11	12+
89940	1/4-20	1-1/2"	Ea	7.00	6.84
89942	3/8-16	1-1/2"	Ea	7.11	6.95
89951	5/16-24	1-1/2"	Ea	11.09	10.83

CUTTING TOOLS / EXTRACTOR SETS

J) Extractor Sets

Screw and pipe. Qualifying Standard: Rutland Tool.

KCDA No.	Description	U/M	1-17	18+
86834	Easy-out set, sizes: 1 - 5	Ea	10.79	10.53

CUTTING TOOLS / FILES

K) File Card

9-1/2" long, combination file card and brush. The file card is made with sharp steel bristles to dig and quickly remove shavings from grooves of files to restore their clean cutting capacity. The brush side has longer and softer bristles and is used especially to remove filings on finer cut files. Also to brush clean saws, drill bits and in other areas where a brush is needed. Qualifying Standard: Lutz.

KCDA No.	U/M	1-23	24+
86990	Ea	9.60	9.45

2011 KCDA CATALOG

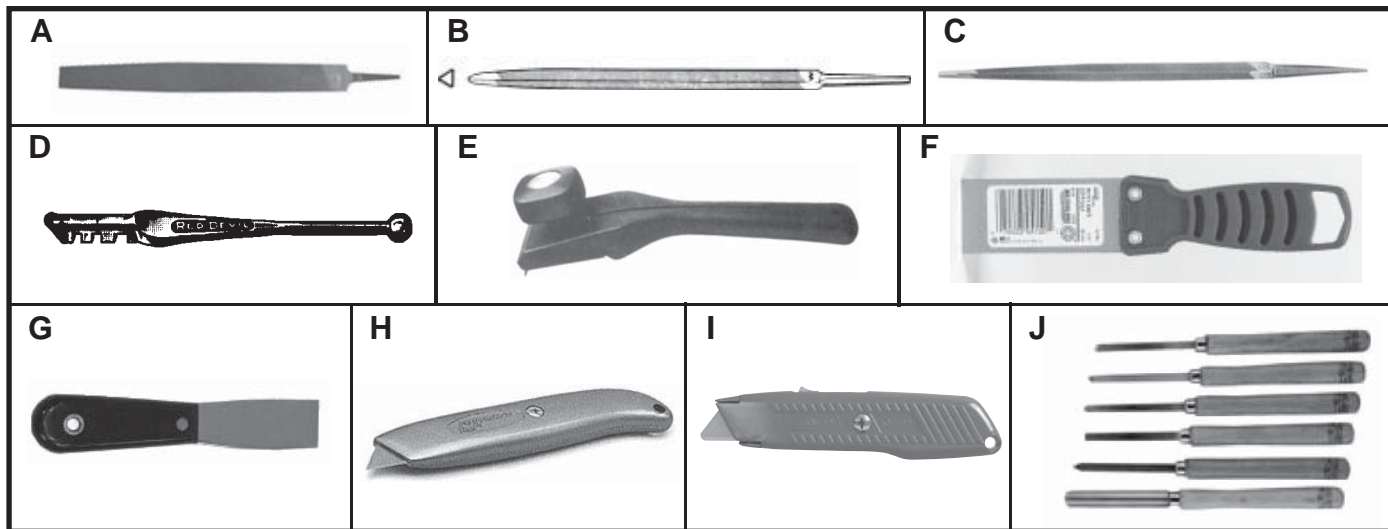

A) 10" Files

Qualifying Standard: Simonds.

KCDA No.	Cut	Description	U/M	1-23	24+
86870	Bastard	Flat	Ea	5.19	5.07
86871	Second Cut	Flat	Ea	5.98	5.84
86872	Smooth	Flat	Ea	6.54	6.39
86890	Bastard	Half Round	Ea	7.45	7.27
86891	Second Cut	Half Round	Ea	8.07	7.88
86874	Bastard	Mill	Ea	3.47	3.39
86875	Second Cut	Mill	Ea	4.69	4.58
86876	Smooth	Mill	Ea	5.00	4.88
86893	Bastard	Round	Ea	4.11	4.01
86900	Second Cut	Round	Ea	4.84	4.73
86877	Bastard	Square	Ea	6.02	5.88

B) Taper Files, Regular

Triangular single cut files with edges or corners set (blunted) and cut to maintain proper gullet shape on saws with 60° angle teeth. Qualifying Standard: Warrenville.

KCDA No.	Description	U/M	1-47	48+
86840	6", 15/32	Ea	2.65	2.61
86841	8", 19/32	Ea	4.14	4.08

C) Taper Files, Slim

For sharpening buck saws and hand saws. Double cut is recommended for use in saw filing machines. Qualifying Standard: Warrenville.

KCDA No.	Description	U/M	1-47	48+
86845	6", 21/64	Ea	2.19	2.15

CUTTING TOOLS / GLASS CUTTER

D) Glass Cutter

Qualifying Standard: Red Devil.

KCDA No.	U/M	1-47	48+
86685	Ea	2.72	2.68

CUTTING TOOLS / HOOK SCRAPER

E) Hook Scraper

2-1/2" with two serrated and two plain cutting edges. Replacement blades available, see KCDA No. 87453. Qualifying Standard: Red Devil.

KCDA No.	U/M	1-23	24+
87452	Ea	7.65	7.54

CUTTING TOOLS / KNIVES / PUTTY

F) Putty Knife

Ergonomically designed and tested one piece handle. Rugged, red polypropylene handle resists most common paint thinners. High carbon steel blade. Each blade tempered, ground and satin finished. 1-1/2"x3" stiff blade. Qualifying Standard: Hyde.

KCDA No.	U/M	1-35	36+
87221	Ea	1.28	1.26

G) Putty Knife

1-1/4" x 3-1/2" flex blade. Qualifying Standard: Great Neck.

KCDA No.	U/M	1-35	36+
87220	Ea	2.46	2.42

CUTTING TOOLS / KNIVES / UTILITY

H) Utility Knife

Aluminum handle with retractable blade. Use blades KCDA Nos. 87223 and 87229. Qualifying Standard: Wilmar.

KCDA No.	U/M	1-35	36+
87227	Ea	3.06	3.01

I) Utility Knife

Safety, self-retracting, use KCDA Blade Nos. 87223 and 87229. Qualifying Standard: Stanley.

KCDA No.	U/M	1-35	36+
87226	Ea	6.18	6.09

CUTTING TOOLS / LATHE

J) Lathe Tools

Qualifying Standard: Delta, Buck Bros.

KCDA No.	Description	U/M	1-23	24+
87232	1/2" Parting Tool	Ea	10.86	10.61
87233	1/2" Chisel, Round Nose	Ea	10.86	10.61
87234	1/2" Chisel, Reg., Skew	Ea	10.86	10.61
87235	1" Chisel, Reg., Skew	Ea	10.86	10.61
87236	1/2" Chisel, Spear Point	Ea	10.86	10.61

Turning Lathe Gouge

5/8", 6" steel blade, 10" (min) wood handle. Qualifying Standard: Buck Bros.

KCDA No.	U/M	1-23	24+
87239	Ea	14.09	13.76

Please check our website at www.kcda.org - Click on the Supply Link Gold Tab for the most current listing of products and pricing. Pricing in this catalog are as of the printing date and are subject to change without notice.



2011 KCDA CATALOG

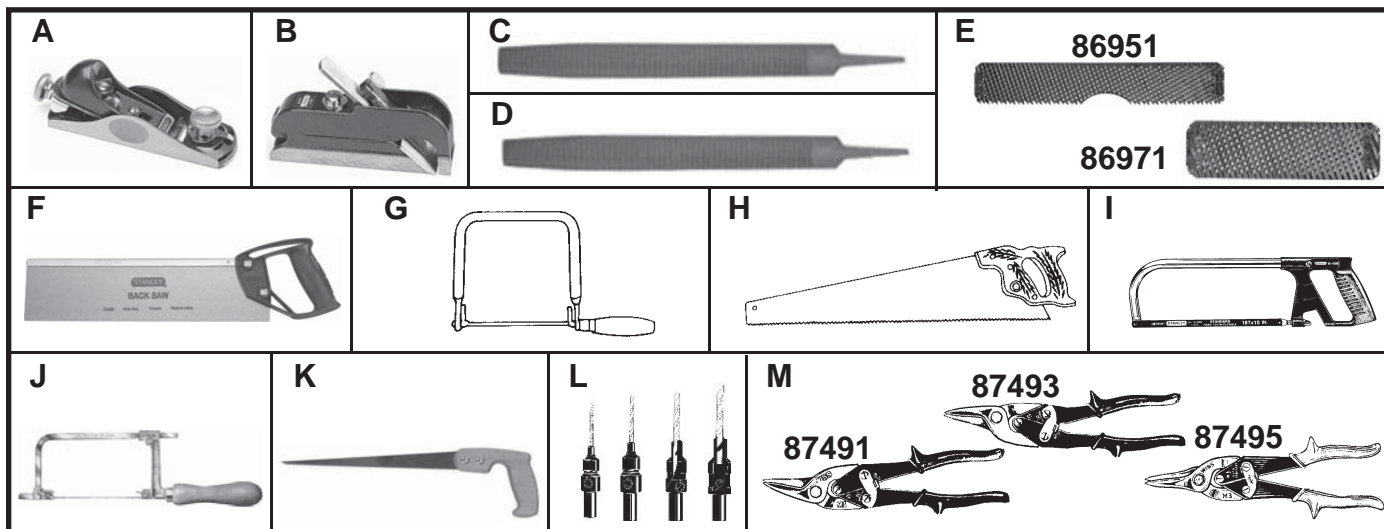

CUTTING TOOLS / PLANES

A) Block Plane, Low Angle

6-1/4" base length, cutter width 1-3/8". ideal for planing end grain and plastic materials. Fully adjustable cutter resting at 21 degrees. 13-1/2 degree low angle cutter. Gray, cast-iron base with precision-ground sides and bottom. Fingergrrips machined into sides make single handed use easy. Hardened, tempered steel gives precision ground cutter edge durability. Cutter adjusts for depth and alignment. Quick release cam lock makes iron removal easy. Qualifying Standard: Stanley.

KCDA No.	U/M	1-11	12+
87260	Ea	39.95	39.01

B) Bullnose Rabbet Plane

4" long, 1-1/8" cutter width. Designed with the cutter at front of plane for close work into corners. Lightweight tool, excellent for trimming rabbets. Mouth adjusts for coarse for fine work. Gray cast-iron body machied on base and sides. Qualifying Standard: Stanley.

KCDA No.	U/M	1-11	12+
87262	Ea	28.92	28.24

CUTTING TOOLS / RASPS

C) 10" Half Round Cabinet Rasp

Second cut. Qualifying Standard: Warrensville.

KCDA No.	U/M	1-23	24+
86850	Ea	13.77	13.45

D) 10" Half Round Wood Rasp

Bastard cut files. Qualifying Standard: Warrensville.

KCDA No.	U/M	1-23	24+
86851	Ea	8.38	8.18

E) Rasp Replacement Blades

Replacement blades for:

KCDA No. 86951 fits KCDA No. 86950.

KCDA No. 86971 fits KCDA No. 86970.

KCDA No. 86961 fits KCDA No. 86960.

Qualifying Standard: Stanley.

KCDA No.	Type	U/M	1-35	36+
86951	Flat Type	Ea	4.57	4.50
86971	Pocket Tool	Ea	3.92	3.86

CUTTING TOOLS / SAWS / BACK

F) Back Saw

14", 13 points per inch. Qualifying Standard: Stanley.

KCDA No.	U/M	1-17	18+
87346	Ea	9.35	9.13

CUTTING TOOLS / SAWS / COPING

G) Coping Saw

6-1/2" depth, 6-1/2" pin end blade. Qualifying Standard: Stanley.

KCDA No.	U/M	1-23	24+
87400	Ea	5.91	5.81

CUTTING TOOLS / SAWS / CROSSCUT

H) Crosscut Saw

26", 10 point. Qualifying Standard: Great Neck.

KCDA No.	U/M	1-11	12+
87405	Ea	17.93	17.50

CUTTING TOOLS / SAWS / HACKSAW

I) Hacksaw

Adjusts 8" to 12". Qualifying Standard: Vermont.

KCDA No.	U/M	1-11	12+
87410	Ea	5.99	5.85

CUTTING TOOLS / SAWS / JEWELERS

J) Jewelers Saw

Adjustable frame, 5" depth. Qualifying Standard: Olson.

KCDA No.	U/M	1-23	24+
87380	Ea	17.65	17.23

CUTTING TOOLS / SAWS / KEYHOLE

K) Keyhole Saw

12". Qualifying Standard: Stanley.

KCDA No.	U/M	1-23	24+
87393	Ea	9.30	9.15

CUTTING TOOLS / SCREW SINK

L) Screw Sink Sets

Countersinks/counterbore, drill set, sizes 6, 8, 10 and 12. Qualifying Standard: General Tool.

KCDA No.	U/M	1-11	12+
86229	4/Set	11.82	11.54

CUTTING TOOLS / SNIPS/SHEARS

M) Aviation Snips

Compound action, vinyl grips. Qualifying Standard: Great Neck.

KCDA No.	Cut	U/M	1-17	18+
87491	Left	Ea	5.88	5.74
87493	Right	Ea	5.88	5.74
87495	Straight	Ea	5.88	5.74

2011 KCDA CATALOG

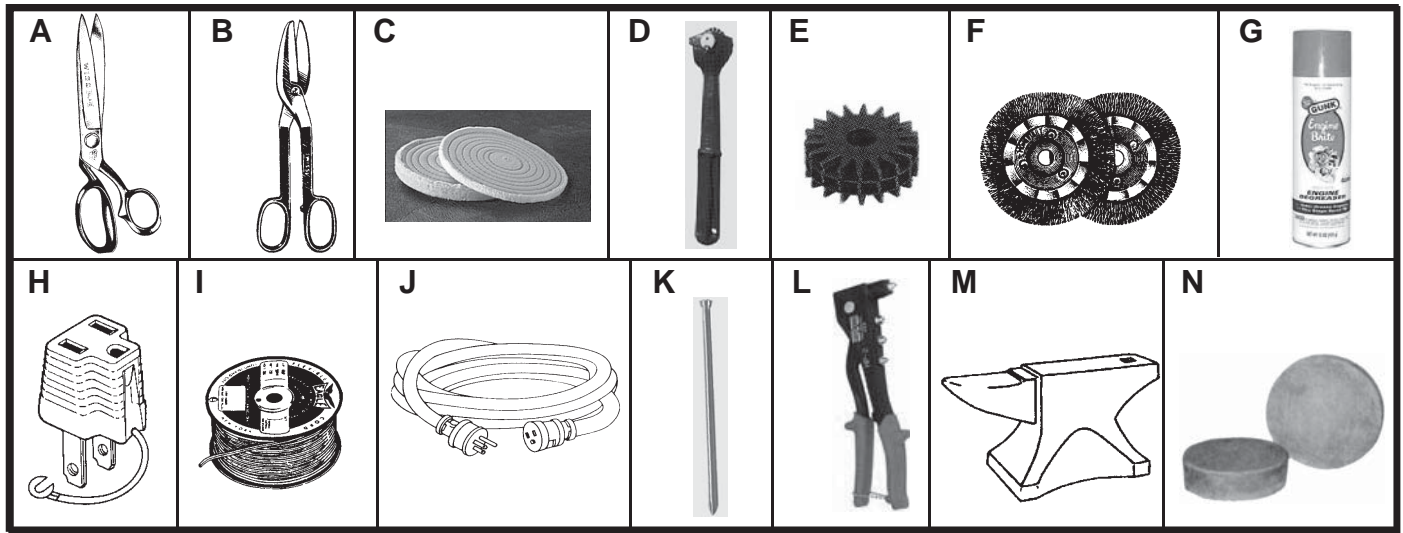

A) Shears

Bent trimmer, 10" long with 5" cut. Qualifying Standard: Wiss.

KCDA No.	U/M	1-11	12+
87450	Ea	32.26	31.50

B) Tiners Snips

Qualifying Standard: Midwest.

KCDA No.	Description	Cut	U/M	1-17	18+
87503	Regular, Straight	2-1/2"	Ea	18.10	17.68
87501	Straight Industrial Snips	3"	Ea	18.08	17.65

CUTTING TOOLS / WHEELS / BUFFING

C) Buffing Wheel

Cotton flannel, 20 ply. 6" x 1-1/4" x 1" arbor, spiral sewn. Qualifying Standard: Formax.

KCDA No.	U/M	1-23	24+
87065	Ea	3.73	3.67

CUTTING TOOLS / WHEELS / DRESSER & CUTTER

D) Hooded Wheel Dresser

Up to 10" diameter wheels. Qualifying Standard: Desmond.

KCDA No.	U/M	1-17	18+
87100	Ea	12.74	12.55

E) Wheel Dresser Cutter

Cutter for wheel dresser KCDA item 87100. Qualifying Standard: Huntington.

KCDA No.	U/M	1-143	144+
87101	Ea	1.89	1.86

CUTTING TOOLS / WHEELS / WIRE

F) Wire Wheels

6"x3/4" wide. Qualifying Standard: Hamburg.

KCDA No.	Desc	Type	U/M	1-23	24+
87092	5/8" Arbor	Coarse .014 Wire	Ea	13.21	12.90
87085	1/2" Arbor	Fine .008 Wire	Ea	37.06	36.19

DEGREASER/CLEANER

G) Degreaser and Cleaner

Aerosol, 16oz. Qualifying Standard: Gunk.

KCDA No.	U/M	1-47	48+
88182	1/Can	4.39	4.28

Please check our website at www.kcda.org - Click on the Supply Link Gold Tab for the most current listing of products and pricing. Pricing in this catalog are as of the printing date and are subject to change without notice.

ELECTRICAL / ADAPTOR

H) Adaptor Plug

125 Volt, 14 Gauge plug. Makes three-prong cord fit two-prong outlet. Qualifying Standard: Coleman.

KCDA No.	U/M	1-47	48+
86832	Ea	1.46	1.44

ELECTRICAL / CORD

I) Electrical Cord

Rolls, plastic, 250' long, U.L. 18 gauge - 2 wire. Qualifying Standard: Pacific Electricord.

KCDA No.	Color	U/M	1-11	12+
88773	White	1/Roll	39.36	38.43

J) Extension Cords

300 Volt-125V rating, 15 amp, 14/3, type S Neoprene. Qualifying Standard: Coleman.

KCDA No.	Length	U/M	1-17	18+
86829	15	Ea	6.81	6.65
86830	25	Ea	12.92	12.61
86831	50	Ea	22.57	22.04

FASTENERS / BRADS

K) Wire Brads

Steel wire.

KCDA No.	Size	Gauge	U/M	1-10	11+
88897	1-1/4"	18	1 Lb/Box	2.77	2.73

FASTENERS / RIVETS

L) Blind Rivet Tool

With four interchangeable dies: 3/32", 1/8", 5/32" and 3/16". Qualifying Standard: Tools Exchange.

KCDA No.	U/M	1-5	6+
87324	Ea	31.30	30.56

FOUNDRY / ANVILS

M) Anvils

Steel face. Qualifying Standard: Jet.

KCDA No.	Weight	U/M	1-3	4+
86001	110 lbs	Ea	697.03	685.65

FOUNDRY / CRUCIBLE BASE BLOCKS

N) Crucible Base Blocks

Silicon carbide.

KCDA No.	Size	U/M	1-23	24+
87008	7"x2"	Ea	54.47	53.63

2011 KCDA CATALOG

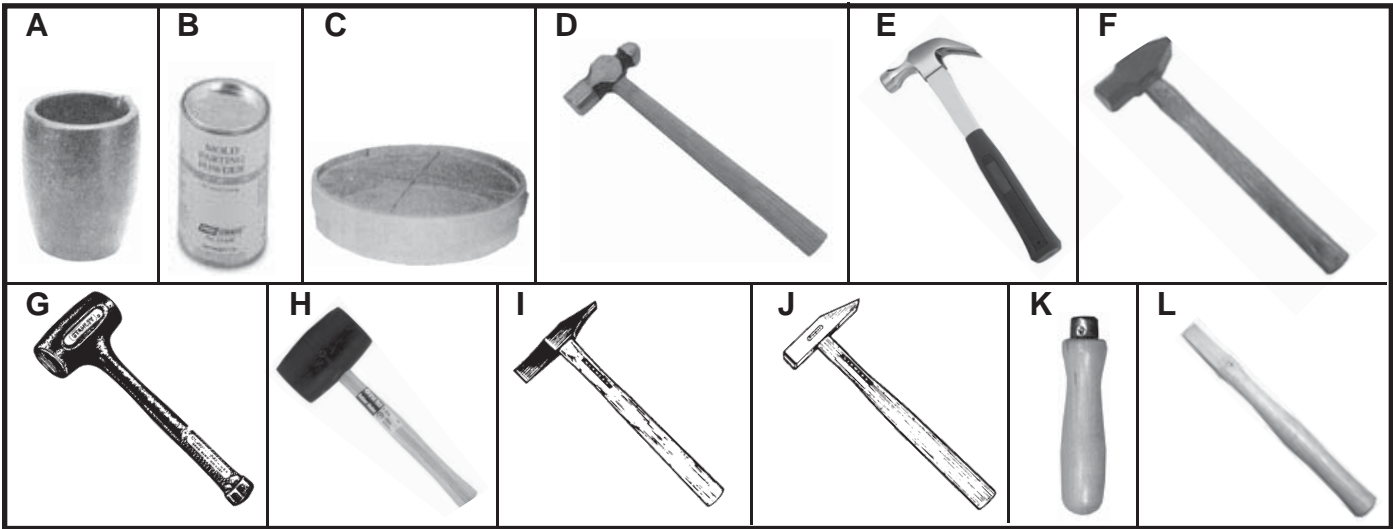

FOUNDRY / CRUCIBLES

A) Graphite Crucibles
Qualifying Standard: Brodhead-Garrett.

KCDA No.	Description	U/M	1-5	6+
87004	#10 for Johnson #510 Furnace	Ea	93.28	91.08

FOUNDRY / PARTING POWDER

B) Parting Powder
Provides clean mold separation, white, 1 pound. Qualifying Standard: Procraft.

KCDA No.	U/M	1-11	12+
88169	1/Jar	3.54	3.48

FOUNDRY / RIDDLE

C) Riddles
3"x18" diameter, 3-ply laminate rim galvanized wire screen and cross wires. Qualifying Standard: Paxton Patterson.

KCDA No.	Description	U/M	1-11	12+
87020	8 Mesh	Ea	56.74	55.40

FOUNDRY / SAND

Molding Sand
Qualifying Standard: Petrobond.

KCDA No.	Pack	U/M	1-5	6+
88160	100 Lb	1/Drum	84.75	83.39

HAMMERS / BALL PEIN

D) Ball Pein Hammers
Qualifying Standard: Stanley Barco.

KCDA No.	Weight	U/M	1-23	24+
87131	4 Oz	Ea	8.70	8.49
87133	8 Oz	Ea	7.38	7.21
87134	12 Oz	Ea	7.70	7.52
87135	16 Oz	Ea	9.47	9.25
87136	20 Oz	Ea	10.39	10.15
87137	24 Oz	Ea	12.07	11.79
87138	32 Oz	Ea	12.95	12.65

HAMMERS / CLAW

E) Curved Claw Hammer
Qualifying Standard: Stanley Barco.

KCDA No.	Handle	Weight	U/M	1-11	12+
87143	Fiberglass	13 Oz	Ea	15.52	15.15
87142	Fiberglass	16 Oz	Ea	9.87	9.64
87146	Wood	13 Oz	Ea	6.49	6.34
87145	Wood	16 Oz	Ea	6.71	6.55

HAMMERS / CROSS PEIN

F) Cross Pein Hammer
Qualifying Standard: Barco.

KCDA No.	Weight	U/M	1-11	12+
87152	48 Oz	Ea	13.16	12.85

HAMMERS / MALLET

G) Dead Blow Hammer
Soft face, 1-1/2 lb., 1-1/2" diameter face. Qualifying Standard: Rutland.

KCDA No.	U/M	1-11	12+
87156	Ea	28.24	27.58

H) Rubber Mallet Hammer
30 ounce, 3"x4-1/2". Qualifying Standard: Great Neck.

KCDA No.	U/M	1-23	24+
87170	Ea	5.85	5.71

HAMMERS / SCALING

I) Scaling Hammer
16 ounce. Qualifying Standard: Osborne.

KCDA No.	U/M	1-11	12+
87149	Ea	27.80	27.14

HAMMERS / SETTING

J) Setting Hammer
12 ounce. Qualifying Standard: Osborne.

KCDA No.	U/M	1-11	12+
87161	Ea	19.53	19.07

HANDLES / FILE

K) File Handles
Wood file handles with metal ferrule. Qualifying Standard: Lutz.

KCDA No.	For	U/M	1-23	24+
86976	8 to 10" Files	Doz	11.68	11.40
86977	10 to 14" Files	Doz	12.70	12.40

HANDLES / HAMMER

L) Hammer Handles
Hickory handles. Qualifying Standard: Sequatchie.

KCDA No.	Type	Weight	Length	U/M	1-47	48+
87182	Machinist	4 oz	10"	Ea	3.86	3.80
87184	Machinist	14-16 oz	14"	Ea	4.04	3.98
87185	Riveting	9 oz	12"	Ea	4.11	4.04

2011 KCDA CATALOG

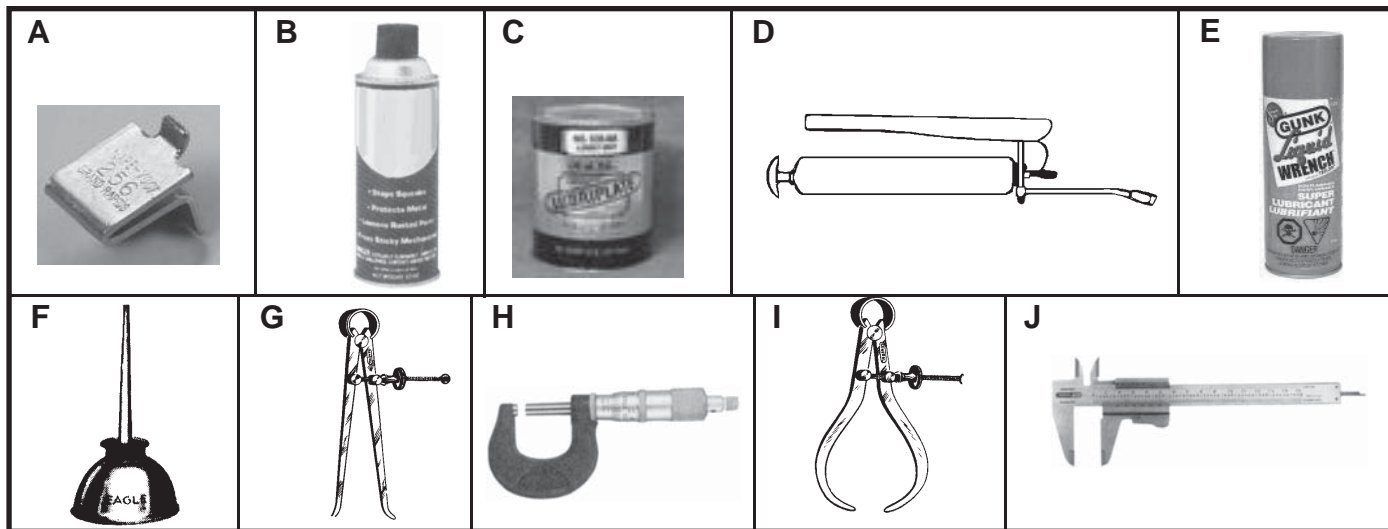

HARDWARE / SUPPORTS

A) Shelf Supports

For showcase standard KCDA item 88840, 3/4" long x 5/8" wide. Zinc finish. Qualifying Standard: KV.

KCDA No.	U/M	1-11	12+
88843	100/Box	15.70	15.45

LACQUERS

Brushing Lacquer

Qualifying Standard: Matson.

KCDA No.	Desc	U/M	1-23	24+
88281	Clear, Gloss	Gal	32.42	31.66

Spraying Lacquer

Qualifying Standard: Matson.

KCDA No.	Finish	U/M	1-23	24+
88285	Clear, Flat	Gal	31.86	31.11

Spraying Lacquer

Spraying Lacquer

KCDA No.	Finish	U/M	1-23	24+
88286	Clear, Gloss	Gal	31.79	31.04

LINSEED OIL

Linseed Oil

Oil, boiled linseed. Qualifying Standard: Sunnyside.

KCDA No.	U/M	1-23	24+
88321	Gal	28.70	28.02

LUBRICANTS / FLUID

B) Lubrication Fluid

12 ounce spray. Qualifying Standard: WD-40.

KCDA No.	U/M	1-71	72+
88877	1/Can	3.48	3.43

LUBRICANTS / GREASE

C) Lubricant Grease

White lithium grease, 1 pound can. Qualifying Standard: Lubriplate.

KCDA No.	U/M	1-23	24+
88880	1/Can	4.87	4.79

LUBRICANTS / GREASE GUN

D) Grease Gun

Lever action, ridged nozzle. Qualifying Standard: Plews.

KCDA No.	U/M	1-5	6+
87106	Ea	10.45	10.21

LUBRICANTS / LOCK

E) Lock Lubricant

12 ounce spay, Teflon. A penetrating, petrol based lubricant with Teflon. Qualifying Standard: Gunk.

KCDA No.	U/M	1-23	24+
88875	1/Can	4.01	3.95

LUBRICANTS / OIL CAN

F) Oil Can

Welded steel bench, 1/3 pint. Qualifying Standard: Plews.

KCDA No.	U/M	1-47	48+
87256	Ea	4.17	4.11

LUBRICANTS / THREAD CUTTING

Thread Cutting Oil

Sulphered, dark. Qualifying Standard: Cully.

KCDA No.	U/M	1-23	24+
88878	Gal	20.92	20.43

MEASURING / CALIPERS

G) Inside Caliper

6" calipers have hardened measurement faces and meet government specifications. GGG-C-95. Qualifying Standard: General.

KCDA No.	U/M	1-23	24+
86510	Ea	3.57	3.49

H) Micrometer Calipers

Outside. Qualifying Standard: Rutland.

KCDA No.	Size	U/M	1-3	4+
87240	0" to 1"	Ea	12.67	12.38
87241	1" to 2"	Ea	26.61	25.98
87242	2" to 3"	Ea	31.76	31.01

I) Outside Caliper

6" calipers have hardened measurement faces and meet government specifications GGG-C-95. Qualifying Standard: Rutland.

KCDA No.	U/M	1-23	24+
86511	Ea	3.57	3.49

J) Vernier Caliper

6" graduated: .001 and 1/20 mm increments. Stainless steel with satin finish, black engraved markings for O.D., I.D. and depth measurements. Qualifying Standard: Rutland.

KCDA No.	U/M	1-5	6+
86520	Ea	12.46	12.16

2011 KCDA CATALOG

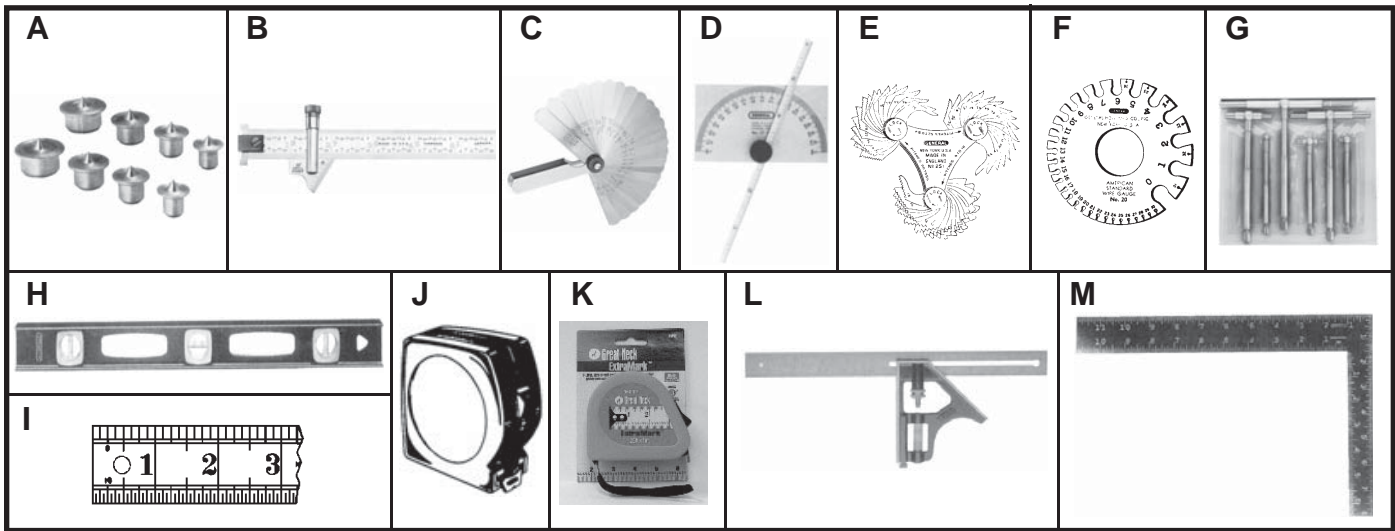

MEASURING / GAUGES

A) Dowel Centers

Contains: two each of: 1/4", 5/16", 3/8", and 1/2" diameter, for spotting holes to match joint work. Qualifying Standard: General.

KCDA No.	U/M	1-47	48+
86740	8/Set	1.96	1.93

B) Drill Point Gauge

For determining correct 59 degree point angle and correct length of drill lips necessary for clean cut drilling at maximum feeds and speeds. Consists of 6" hook rule with sliding head that can be locked anywhere by knurled thumb nut. Head is beveled to 59 degrees and graduated in 32nds. Hook rule is graduated in 8ths, 16ths, 32nds and 64ths. Qualifying Standard: Starrett.

KCDA No.	U/M	1-7	8+
87046	Ea	53.07	51.82

C) Feeler Gauge

26 straight leaves.

KCDA No.	U/M	1-23	24+
87059	Ea	7.39	7.28

D) Protractor and Depth Gauge

Semicircular, 6" blade, graduations from 0 - 180 degrees in opposite directions, stainless steel. Qualifying Standard: General.

KCDA No.	U/M	1-5	6+
87297	Ea	16.33	15.95

E) Screw Pitch Gauge

51 leaf. Combines all sizes from 4 to 84, including 11-1/2 and 27 pipe thread sizes. Qualifying Standard: General.

KCDA No.	U/M	1-23	24+
87050	Ea	42.10	41.11

F) Sheet and Wire Gauge

U.S. Standard. For gauging wire, sheets, plates, of nonferrous metals such as copper, brass, aluminum, etc. Decimal equivalents of each size are shown on reverse side. Made of hardened steel, 3-1/4" diameter and 1/8" thick. Qualifying Standard: General.

KCDA No.	U/M	1-23	24+
87052	Ea	21.14	20.64

Please check our website at www.kcda.org - Click on ordering and Supply Link for the most current listing of products and pricing. Pricing in this catalog are as of the printing date and are subject to change without notice.

G) Telescoping Gauge Set

Set of four: AA-A-B-C, with case. For measuring inside diameters, widths of holes and slots from which accurate micro meter measurements are taken. Hardened and precision ground. Qualifying Standard: General.

KCDA No.	U/M	1-7	8+
87057	4/Set	86.41	84.37

MEASURING / LEVEL

H) Level

24", aluminum, one level vial, two plumb vials. Qualifying Standard: Great Neck.

KCDA No.	U/M	1-7	8+
87238	Ea	9.17	8.95

MEASURING / RULES

I) Steel Bench Rules

1-1/4" wide, 1/16" thick. Tempered steel, "hang-up" hole in one end. Markings are deeply etched and black-filled for easy reading, marked both sides, both edges-upper edge in 8ths and lower edge in 16ths. Qualifying Standard: Lufkin.

KCDA No.	Length	U/M	1-11	12+
87327	1'	Ea	25.87	25.26

KCDA No.	Length	U/M	1-7	8+
87329	3'	Ea	64.31	62.80

J) Steel Tape Rules

Qualifying Standard: Stanley.

KCDA No.	Width	Length	U/M	1-23	24+
87333	1/2"	10	Ea	2.51	2.47
87336	1/2"	12	Ea	3.21	3.16

K) Steel Tape Rules

Qualifying Standard: Great Neck.

KCDA No.	Width	Length	U/M	1-23	24+
87334	1"	25	Ea	7.36	7.24

MEASURING / SQUARES

L) Combination Square

12", Slotted with one level vial. Qualifying Standard: Stanley.

KCDA No.	U/M	1-23	24+
87509	Ea	8.44	8.24

M) Flat Square

12" x 1-1/2": Tongue: 8" x 1", Graduations: 1/16.

KCDA No.	U/M	1-23	24+
87511	Ea	4.25	4.15

2011 KCDA CATALOG

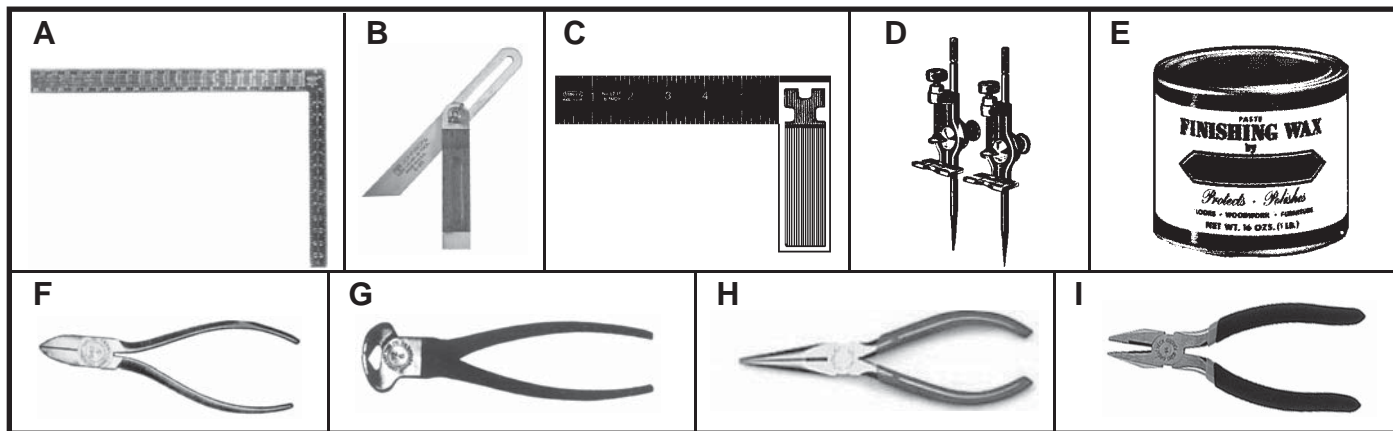

A) Framing Steel Square

Flat framing: 24" x 2", tongue: 16" x 1-1/2" graduations: 1/16, 1/8, 1/16, 1/10, 1/12. Qualifying Standard: Stanley.

KCDA No.	U/M	1-23	24+
87510	Ea	9.36	9.14

B) Sliding "T" Bevel Square

8" blade, 5" hardwood handle. Qualifying Standard: Johnson.

KCDA No.	U/M	1-23	24+
87518	Ea	12.25	11.96

C) Try Squares

1/8" graduation. Qualifying Standard: Fairgate.

KCDA No.	Handle	Blade	U/M	1-23	24+
87513	5-1/2"	8"	Ea	11.84	11.57

MEASURING / TRAMMEL POINTS

D) Carpenters Trammel Points

6" off center eccentric points. Points can be replaced with pencils, ball point pens, crayons or soapstone sticks. 2 per set. Qualifying Standard: General.

KCDA No.	U/M	1-23	24+
87298	2/Set	34.27	33.47

PAINT

Enamel Spray Paint

Fast dry, 12 ounce spray can. Qualifying Standard: Zynolyte.

KCDA No.	Color	U/M	1-7	8+
88306	Black	6/Case	19.58	19.12
88314	Blue, Berm	6/Case	19.58	19.12
88307	Clear	6/Case	19.58	19.12
88303	Gray	6/Case	19.58	19.12
88309	Green	6/Case	19.58	19.12
88311	Orange	6/Case	19.58	19.12
88304	Red	6/Case	19.58	19.12
88308	White	6/Case	19.58	19.12
88305	Yellow	6/Case	19.58	19.12

Fast Dry Spray Paint

Flat black, 13 ounce spray cans. Qualifying Standard: Zynolyte.

KCDA No.	U/M	1-7	8+
88313	6/Case	19.58	19.12

Safety Coding Paint

General use enamel paint, fast drying. Qualifying Standard: Farwest.

KCDA No.	Color	U/M	1-17	18+
88270	Green	Qt	14.67	14.45
88271	Orange	Qt	16.82	16.56
88268	Red	Qt	15.73	15.49
88272	Yellow	Qt	15.81	15.57

PAINT REMOVER

Mineral Spirits

Qualifying Standard: Farwest.

KCDA No.	U/M	1-23	24+
33450	Gal	13.30	13.09

KCDA No.	U/M	1-17	18+
33460	5 Gal/Can	86.44	84.41

Paint Remover

Wash away. Qualifying Standard: Farwest.

KCDA No.	U/M	1-11	12+
88181	Gal	37.14	36.57

PASTE WAX

E) Paste Wax Finishing

Wood finishing, clear. Qualifying Standard: Johnson Wax.

KCDA No.	U/M	1-17	18+
88322	1 Lb/Can	7.87	7.75

PASTE WOOD FILLERS

Wood Paste Fillers

Qualifying Standard: Daly's.

KCDA No.	Color	U/M	1-23	24+
88195	Walnut	Qt	11.44	11.17

PLIERS

F) Diagonal Pliers

6". Qualifying Standard: Crescent.

KCDA No.	U/M	1-23	24+
87278	Ea	5.20	5.08

G) End Cutter

7". Qualifying Standard: Chanelok.

KCDA No.	U/M	1-23	24+
87280	Ea	19.25	18.80

Flat Nose Pliers

7". Qualifying Standard: Crescent.

KCDA No.	U/M	1-22	23+
87277	Ea	17.75	17.33

H) Needle Nose Pliers

6-1/2". Qualifying Standard: Crescent.

KCDA No.	U/M	1-23	24+
87271	Ea	5.71	5.58

I) Side Cutting Pliers

6"-3/4". Qualifying Standard: Crescent.

KCDA No.	U/M	1-23	24+
87273	Ea	6.16	6.01

2011 KCDA CATALOG

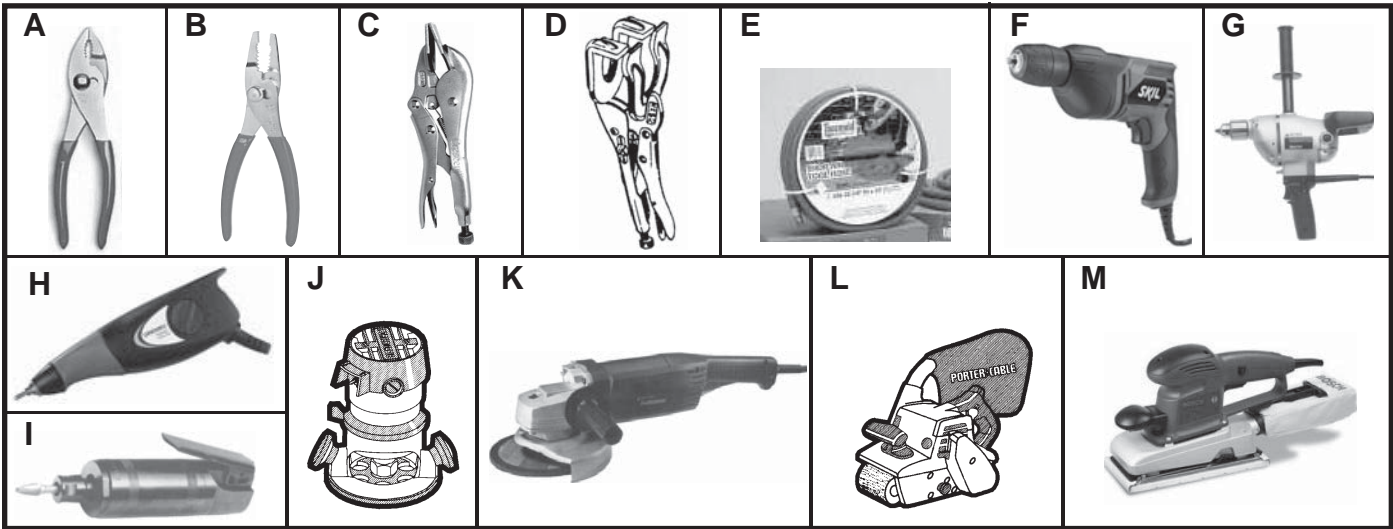

A) Slip Jaw Pliers

6". Qualifying Standard: Crescent.

KCDA No.	U/M	1-23	24+
87276	Ea	5.97	5.83

B) Thin Nose Pliers

6". Qualifying Standard: Crescent.

KCDA No.	U/M	1-23	24+
87270	Ea	6.86	6.70

C) Tinner Pliers

Vise grip, Qualifying Standard: Crescent.

KCDA No.	U/M	1-23	24+
87291	Ea	15.67	15.30

D) Welding Pliers

9". Qualifying Standard: Petersen.

KCDA No.	U/M	1-23	24+
87290	Ea	18.95	18.50

POWER TOOLS / AIR HOSE

E) Pneumatic Air Hose

3/8" I.D., 250 P.S.I. capacity. 25' length with adaptors for fittings. Qualifying Standard: Thermold.

KCDA No.	U/M	1-11	12+
86773	Ea	34.97	34.15

POWER TOOLS / DRILL

F) Portable Electric Drill

Powerful 6.5 amp motor; 0-2,000 RPM for handling a variety tough applications. 3/8" keyless chuck for quick and easy bit changes. Variable speed trigger for the ability to easily go from low to high speeds. Built-in Level for precise horizontal and vertical drilling. Qualifying Standard: Skil.

KCDA No.	U/M	1-5	6+
87656	Each	61.24	60.24

G) Portable Electric Drill

1/2", 7.0 amp motor, pistol grip auxiliary handles (pipe and spade), 450 rpm, 9-3/4 pounds. Qualifying Standard: Milwaukee.

KCDA No.	U/M	1
87658	Ea	108.49

Please check our website at www.kcda.org - Click on ordering and Supply Link for the most current listing of products and pricing. Pricing in this catalog are as of the printing date and are subject to change without notice.

POWER TOOLS / ENGRAVER

H) Vibro Engraver

Good on hardened steel, ceramics or glass. Calibrated stroke adjustment, 7,200 strokes per minute. Qualifying Standard: Dremel.

KCDA No.	U/M	1-5	6+
87580	Ea	20.73	20.24

POWER TOOLS / GRINDER

I) Die Grinder

Air. 25,000 rpm with 1/4" collet and wrench. Lever action teasing throttle. Qualifying Standard: Chicago Pneumatic.

KCDA No.	U/M	1-5	6+
86757	Ea	34.85	34.56

POWER TOOLS / ROUTER

J) Portable Electric Router

1-1/2 h.p. heavy duty, 23,000 rpm, 10 amp micrometer adjustment. Qualifying Standard: Porter Cable.

KCDA No.	U/M	1-5	6+
87672	Ea	179.22	176.29

POWER TOOLS / SANDERS

K) Angle Sander

Portable electric, 15 amp, 7" diameter backup pad, 6,000 rpm. Qualifying Standard: Milwaukee.

KCDA No.	U/M	1-5	6+
87676	Ea	205.08	201.73

L) Belt Sander

Portable electric, 3" x 24" belts with dust bag. Qualifying Standard: Porter Cable.

KCDA No.	U/M	1-5	6+
87679	Ea	303.18	300.66

M) Orbital Finishing Sander

3.2 Amps, 11,000. Rubberized paper clamps, also accepts stick-on paper and includes a dual row bearing design. Through-the-pad dust extraction pulls dust away from work surface. Handles, tapered soft-grip top with multiple grip positions. Front handle removes for sanding in tight spots. Trigger switch with lock-on button. Punch plate included perforates standard paper for dust collection. Flush sanding ability sands close to vertical surfaces on three sides. Qualifying Standard: Bosch 1293D.

KCDA No.	U/M	1-5	6+
87681	Ea	194.82	191.64

2011 KCDA CATALOG

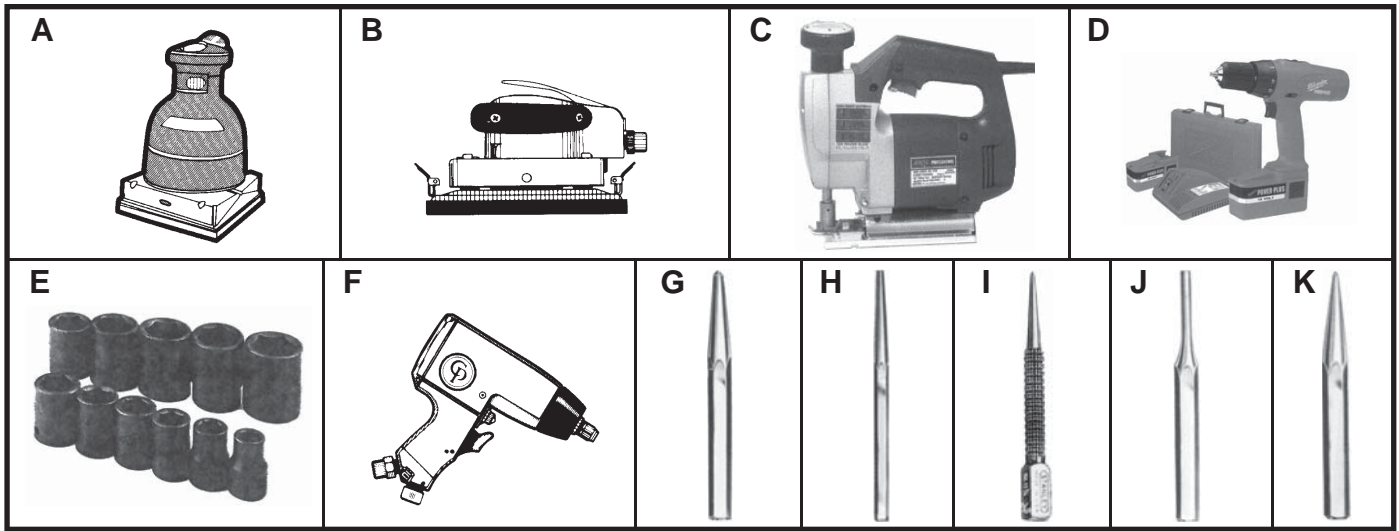

A) Orbital Finishing Sander

Speed block, 14,000 opm, 4-1/8" x 4-1/2" pad size. Qualifying Standard: Porter Cable.

KCDA No.	U/M	1-5	6+
87680	Ea	111.27	109.48

B) Orbital Sander

Pneumatic, air, rectangular palm held. Foam rubber pad, two paper clamps pad size 3-1/2" x 9", 8,000 cycles per minute, 1/4" NPTF. Qualifying Standard: Spartan.

KCDA No.	U/M	1-5	6+
86758	Ea	77.46	76.22

POWER TOOLS / SAW

C) Jig Saw

Electric, variable speed, 115 volt, 3.5 amp., 0-3,200 rpm, capacity: 2" wood, 3/8" aluminum, 3/16" steel. Qualifying Standard: Skill.

KCDA No.	U/M	1-5	6+
87688	Ea	121.25	119.27

POWER TOOLS / SCREWDRIVER

D) Cordless Drill/Drive Kit

Variable two speed 3/8" driver/drill with keyless chuck. Includes: driver/drill, two 1.4 amp-HR. power-plus battery packs, power-plus charger and impact resistant carrying case. Qualifying Standard: Skill.

KCDA No.	U/M	1-5	6+
87661	Ea	224.05	220.39

POWER TOOLS / SOCKET SETS

E) Impact Socket Set

11 piece 6 point standard fractional set. Contains: 1/2", 9/16", 5/8", 11/16", 3/4", 13/16", 7/8", 15/16", 1", 1-1/16", 1-1/8" sockets. Packaged on a metal rail. Qualifying Standard: Armstrong.

KCDA No.	U/M	1-5	6+
87636	11/Set	85.83	83.81

POWER TOOLS / WRENCH

F) Impact Wrench

Air, 1/2" drive, friction ring retainer, pin clutch, torque range: 28 to 135 feet per pound, 1/4" NPTF. Qualifying Standard: Ingersol Rand.

KCDA No.	U/M	1-5	6+
86766	Ea	71.15	70.57

PRIMERS

Primer

Zinc chromate #1002. Qualifying Standard: Farwest.

KCDA No.	U/M	1-23	24+
88187	Pint	19.49	19.19

PUNCH / CENTER PIN

G) Center Pin Punch

Hex, 1/8" x 4-1/4". Qualifying Standard: Mayhew.

KCDA No.	U/M	1-47	48+
87300	Ea	2.90	2.86

PUNCH / DRIFT

H) Drift Punch

Hex, long taper, 3/16" x 10". Qualifying Standard: Mayhew.

KCDA No.	U/M	1-47	48+
87312	Ea	6.72	6.62

PUNCH / NAIL SET

I) Nail Sets

Carbon steel. Qualifying Standard: Stanley.

KCDA No.	Size	U/M	1-47	48+
87250	2/32"	Ea	1.71	1.68
87251	3/32"	Ea	1.71	1.68
87252	4/32"	Ea	1.71	1.68
87249	1/32"	Ea	1.71	1.68

PUNCH / PIN

J) Pin Punch

3/16" x 6". Qualifying Standard: Baltimore.

KCDA No.	U/M	1-47	48+
87316	Ea	3.35	3.30

PUNCH / PRICK

K) Prick Punch

Hex, 3/8" x 5". Qualifying Standard: Great Neck.

KCDA No.	U/M	1-47	48+
87318	Ea	3.85	3.79

Please check our website at www.kcda.org - Click on the Supply Link Gold Tab for the most current listing of products and pricing. Pricing in this catalog are as of the printing date and are subject to change without notice.

2011 KCDA CATALOG

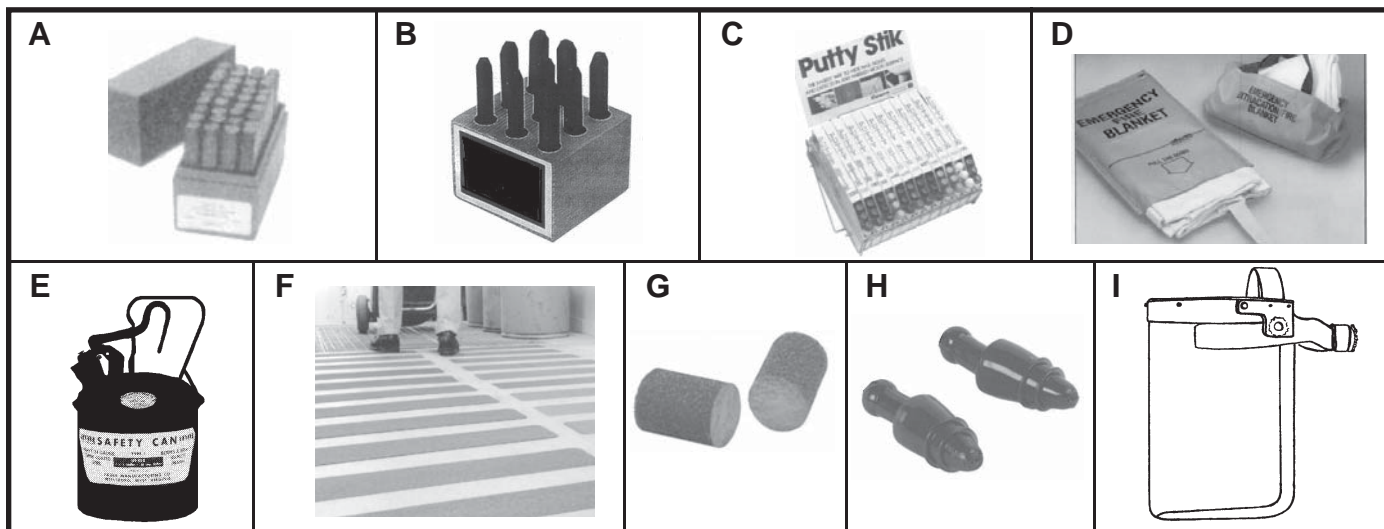

PUNCH / STAMP

A) Steel Letter Stamp Sets

Includes A-Z plus period, 27 characters. Carefully hardened for making nameplates, key checks, tags, tools, etc., durable against rust. Recommended for steel up to hardness RC50. Fitted case included. Qualifying Standard: Young Brothers.

KCDA No.	Size	U/M	1-11	12+
87523	1/8"	27/Set	35.70	34.86
87524	1/4"	27/Set	53.55	52.29

B) Steel Number Stamp Sets

Includes 0-8, 9 can be inverted to make number 6, 9 characters. Carefully hardened for making nameplates, key checks, tags, tools, etc., durable against rust. Recommended for steel up to hardness RC50. Fitted case included. Qualifying Standard: Young Brothers.

KCDA No.	Size	U/M	1-23	24+
87520	1/8"	9/Set	12.09	11.80
87521	1/4"	9/Set	17.85	17.43

PUTTY

Surfacing Putty

4 ounce can. Qualifying Standard: Duratite.

KCDA No.	Color	U/M	1-131	132+
88562	Mahogany, Light	Ea	3.04	2.97
88561	Oak	Ea	3.04	2.97
88563	Pine	Ea	3.04	2.97
88564	Walnut	Ea	3.04	2.97

C) Touch Up Putty Sticks

.42 ounces. Qualifying Standard: Darworth.

KCDA No.	Color	U/M	1-71	72+
88548	Oak	Ea	2.08	2.00
88542	Pine/Natural	Ea	2.08	2.00
88547	Walnut, Dark	Ea	2.08	2.00

SAFETY / BLANKETS

D) Fire Blanket

Washable, made of woven fiberglass. Grommets sewn on edges for hanging dry. Blanket size: 5'x6'. In wall hanging pouch with velcro pull tab on bottom for easy release. Qualifying Standard: Sellstrom.

KCDA No.	U/M	1-11	12+
86780	Ea	50.34	49.15

SAFETY / CAN

Oil Waste Can

10 Gallon, self closing, with hand lift and foot lever. Qualifying Standard: Justrite.

KCDA No.	U/M	1-5	6+
87582	Ea	70.35	68.70

E) Safety Cans

For flammable liquids. Qualifying Standard: Justrite.

KCDA No.	Size	U/M	1-7	8+
87337	1 Gallon	Ea	31.11	30.38
87339	5 Gallon	Ea	36.34	35.48

SAFETY / CLEAT

F) Safety Walk Cleat

6" x 24". Self adhering. Qualifying Standard: 3M.

KCDA No.	U/M	1-23	24+
88905	Ea	4.26	4.19

SAFETY / EAR PLUGS

G) Ear Plugs

Disposable. Qualifying Standard: Gateway.

KCDA No.	Pack	U/M	1-11	12+
86823	Pair	200/Box	45.12	44.42

H) Ear Plugs

Silicone, for hearing protection, with plastic case. Qualifying Standard: North.

KCDA No.	U/M	1-71	72+
86821	Pair	0.69	0.68

SAFETY / FACE SHIELDS

Face Shield Visor Replacement

8" x 12" x .040" thick, clear with universal holes. Qualifying Standard: Jackson.

KCDA No.	U/M	1-23	24+
86802	Ea	5.47	5.34

I) Universal Face Shield Visor Mounting

Adjustable headband with rear ratchet knob. Visor tension adjustable, use with KCDA item 86802 visor. Qualifying Standard: Jackson.

KCDA No.	U/M	1-23	24+
86800	Ea	15.15	14.79

2011 KCDA CATALOG

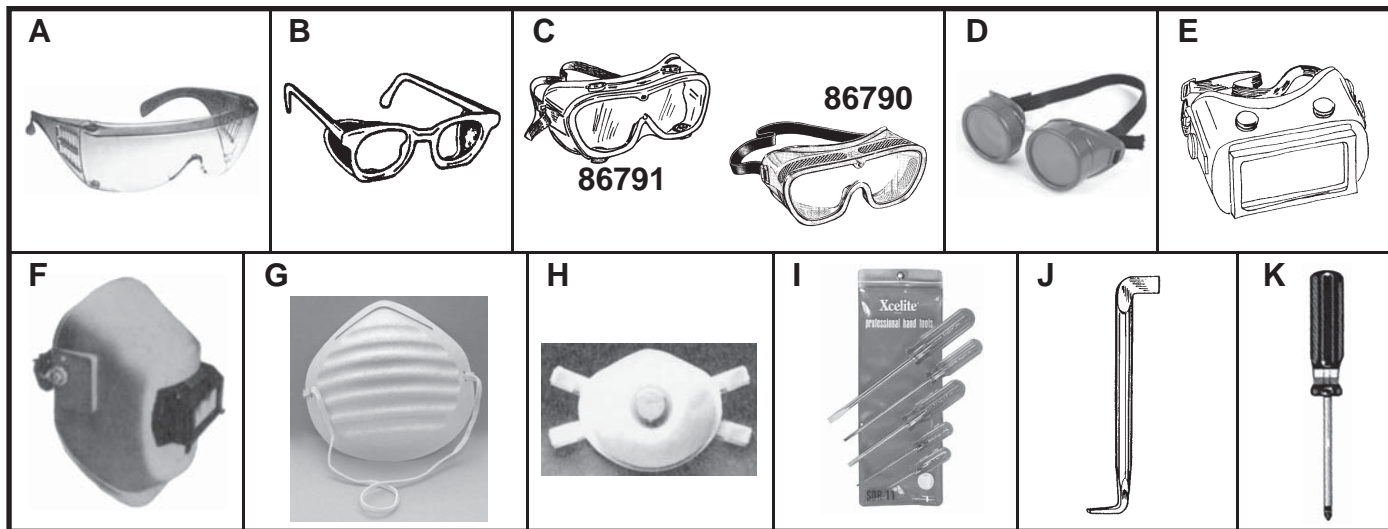

SAFETY / GLASSES

A) Safety Glasses

Clear polycarbonate, 180 degree vision, Z87 rated. Qualifying Standard: Jackson.

KCDA No.	U/M	1-19	20+
86788	Ea	0.96	0.93

B) Safety Glasses

Clear, polycarbonate lenses, plastic cup style side shields, adjustable temples. Qualifying Standard: U.S Safety.

KCDA No.	Size	U/M	1-23	24+
86787	#48, Wide	Ea	4.70	4.59

SAFETY / GOGGLE ACCESSORIES

Welding Goggles Cover Lens

2" x 4-1/4", shatterproof plastic clear lens for welding goggles, KCDA No. 86810.

KCDA No.	U/M	1-71	72+
86813	Ea	0.26	0.25

Welding Helmet Filter Plate Replacement

2" x 4-1/4", shade #10, fits Helmet, KCDA No. 86814. Qualifying Standard: US Safety.

KCDA No.	U/M	1-71	72+
86816	Ea	0.58	0.57

SAFETY / GOGGLES

C) Goggles

Clear vinyl frame, clear .050" polycarbonate lens, elastic headband. Qualifying Standard: SAS, Crews.

KCDA No.	Description	U/M	1-59	60+
86791	Chemical Splash	Ea	2.20	2.12
86790	Safety	Ea	1.53	1.47

D) Welding Goggles

Cup type, shade #5 filter plate, elastic headband. Qualifying Standard: Sellstrom.

KCDA No.	U/M	1-23	24+
86804	Pair	5.07	4.96

E) Welding Goggles

Soft vinyl vented frame, shade #5 filter plates, elastic headband. Qualifying Standard: US Safety.

KCDA No.	U/M	1-23	24+
86810	Ea	7.14	6.97

SAFETY / HELMET

F) Welding Helmet

With flip visor, ratchet headgear, with shade #10 filter plate. For replacement filter plate see KCDA No. 86816. Qualifying Standard: Sellstrom.

KCDA No.	U/M	1-7	8+
86814	Ea	29.83	29.13

SAFETY / MASK

G) Dust and Particle Mask

Paper with headband. For use in dusty shop or work area. Not a substitute for painting type respirators. Qualifying Standard: 3M.

KCDA No.	U/M	1-11	12+
86807	50/Box	4.84	4.73

H) Respirator Mask

Dust/mist/metal fumes, disposable. Treated paper with exhalation valve. Dual headbands, for use in welding (fits under hood), soldering, metal cutting and pouring applications. Qualifying Standard: 3M.

KCDA No.	U/M	1-9	10+
86805	10/Box	35.83	34.98

SCREWDRIVERS / ELECTRICIAN

I) Electricians Screwdriver Set

Slotted, includes: 1/8" x 2", 5/32" x 4", 3/16" x 6", 1/4" x 4", 5/16" x 6". Qualifying Standard: Excelite.

KCDA No.	U/M	1-11	12+
87478	5/Set	30.05	29.34

SCREWDRIVERS / OFFSET

J) Offset Screwdriver

9/32" x 4", for slotted screws. Qualifying Standard: Urrea.

KCDA No.	U/M	1-35	36+
87484	Ea	4.09	4.03

SCREWDRIVERS / PHILLIPS HEAD

K) Phillip Head Screwdrivers

Medium quality, polished high carbon steel blade, impact resistant handles. Qualifying Standard: Irwin.

KCDA No.	Description	U/M	1-35	36+
87474	3" Blade, #1 Point	Ea	1.52	1.49
87475	4" Blade, #2 Point	Ea	1.62	1.59
87476	6" Blade, #3 Point	Ea	2.02	1.99
87477	8" Blade, #4 Point	Ea	4.88	4.81

2011 KCDA CATALOG

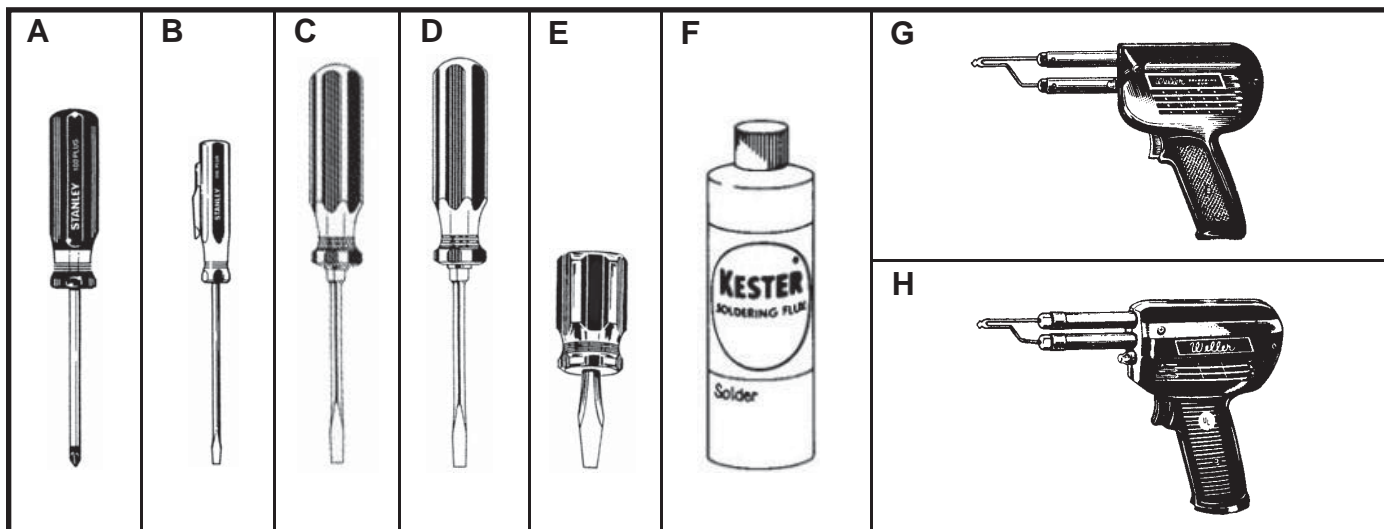

A) Stanley Phillip Head Screwdrivers

Top quality, tempered polished steel blade, flanged stem in a tough composition handle. Stanley 100 Plus, No Substitutes.

KCDA No.	Description	Mfg. No.	U/M	1-35	36+
87470	3" Blade, #1 Point	64-101	Ea	3.43	3.38
87471	4" Blade, #2 Point	64-102	Ea	4.17	4.11
87472	6" Blade, #3 Point	64-103	Ea	5.93	5.84
87473	8" Blade, #4 Point	64-104	Ea	7.71	7.59

SCREWDRIVERS / POCKET

B) Pocket Screwdriver

1/8" x 2" blade. Qualifying Standard: Stanley.

KCDA No.	U/M	1-35	36+
87482	Ea	1.75	1.72

SCREWDRIVERS / SLOTTED HEAD

C) Standard Straight Blade Screwdrivers

Medium quality, impact resistant handle, tempered high carbon steel blade, locktite construction. Qualifying Standard: Irwin.

KCDA No.	Diameter	Blade	U/M	1-23	24+
87465	1/4"	4"	Ea	2.19	2.15
87466	5/16"	6"	Ea	3.21	3.16
87467	3/8"	8"	Ea	4.00	3.94

D) Stanley Slotted Head Screwdrivers

Standard straight blade screwdriver Top quality, boron steel blade and tip, reinforced bolster construction with flanged stem in a tough composition handle. Stanley 100 Plus, No Substitute.

KCDA No.	Dia.	Blade	Mfg. No.	U/M	1-23	24+
87460	1/4"	4"	66-164	Ea	4.66	4.59
87461	5/16"	6"	66-166	Ea	5.52	5.43
87462	3/8"	8"	66-168	Ea	7.04	6.94
87463	3/8"	10"	66-160	Ea	9.45	9.31
87464	3/8"	12"	66-162	Ea	11.10	10.93

SCREWDRIVERS / STUBBY

E) Stubby Screwdriver

1/4" x 1-1/2" straight blade. Qualifying Standard: Great Neck.

KCDA No.	U/M	1-35	36+
87480	Ea	2.02	1.99

SEALERS

Plastic Varnish

Qualifying Standard: Farwest.

KCDA No.	Description	U/M	1-23	24+
88290	Clear, Gloss	Qt	13.32	13.01
88291	Clear, Satin	Qt	14.05	13.72

Sealers

KCDA No.	Description	U/M	1-15	16+
88220	Wood Penetrating	Gal	29.49	28.80

KCDA No.	Description	U/M	1-23	24+
88225	Sanding, Lacquer Base, Clear	Gal	33.02	32.25
88228	Oil Base, Clear	Gal	37.60	36.72

Shellac

Pure white, 3 pound cut.

KCDA No.	U/M	1-23	24+
26010	Qt	14.23	14.01

Varnish

Alcohol and acid proof, clear gloss. Qualifying Standard: Farwest.

KCDA No.	U/M	1-23	24+
88295	Gal	36.15	35.30

SOLDERING / FLUX

F) Soldering Flux

Qualifying Standard: Kester.

KCDA No.	U/M	1-23	24+
88930	1 Qt/Btl	11.11	10.94

SOLDERING / GUN TIPS

Soldering Gun Tips

Universal. Qualifying Standard: Weller.

KCDA No.	Description	U/M	1-47	48+
87108	Heavy Duty Gun	2/Pkg	5.87	5.78
87111	Light Duty Gun	2/Pkg	5.80	5.71

SOLDERING / GUNS

G) Soldering Gun

Heavy duty, 260/200 watts. Highest output gun with trigger selection of heats. Balanced, pistol grip design. Twin lights illuminate work. Heavy gauge, high efficiency copper tips. "Soldering Tips" booklet included. 120v, 60c, AC only. Qualifying Standard: Weller.

KCDA No.	U/M	1-5	6+
87107	Ea	57.03	55.69

H) Soldering Gun

Light duty, 100/140 watts. Fingertip selection of high or low heat output. High efficiency soldering tip of pure copper, pre-tinned, light illuminates work. "Soldering Tips" booklet included. 120v, 60c, AC only. One year guarantee. Qualifying Standard: Weller.

KCDA No.	U/M	1-11	12+
87110	Ea	41.95	40.96

2011 KCDA CATALOG

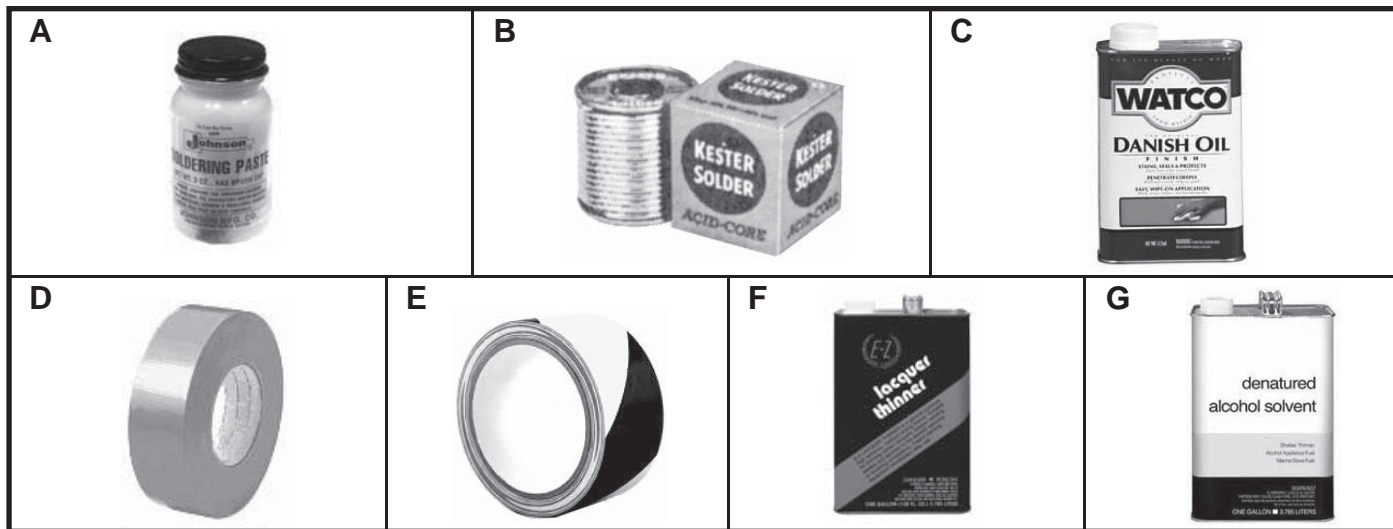

SOLDERING / PASTE

A) Soldering Paste Flux

A quick yet non-aggressive paste flux which does not freeze or decompose. No odor, lead free. Works on copper, galvanized iron, lead, tinned steel and other metals. 3 ounce jar. Qualifying Standard: Johnson.

KCDA No.	U/M	1-23	24+
88936	Ea	2.59	2.51

SOLDERING / SAL AMMONIAC

Sal Ammoniac
Bar form.

KCDA No.	U/M	1-59	60+
88939	1 Lb/Bar	6.71	6.60

SOLDERING / SOLDER

B) Soft Solder

40-60 acid core, 1/8".

KCDA No.	U/M	1-23	24+
88921	1 Lb/Spl	9.23	9.02

Soft Solder

50-50 solid core, 1/8".

KCDA No.	U/M	1-23	24+
88922	1 Lb/Spl	9.49	9.26

Soft Solder

60-40 rosin core, 1/8", 1 pound.

KCDA No.	U/M	1-23	24+
88923	1/Spool	10.88	10.71

STAINS

Oil Base Stains

Qualifying Standard: Farwest.

KCDA No.	Description	U/M	1-17	18+
88235	Victorian Oak	Qt	12.30	12.11
88237	Colonial Maple	Qt	12.30	12.11
88238	Philippine Mahogany	Qt	12.30	12.11
88239	Ebony	Qt	12.30	12.11
88240	Walnut	Qt	12.30	12.11

Please check our website at www.kcda.org - Click on the Supply Link Gold Tab for the most current listing of products and pricing. Pricing in this catalog are as of the printing date and are subject to change without notice.

C) Danish Oil Finish

Seals, hardens, primes and finishes to protect and beautify wood projects. Qualifying Standard: Watco.

KCDA No.	Description	U/M	1-17	18+
88925	Fruitwood	Qt	12.13	11.95
88902	Medium	Qt	12.13	11.95
88900	Natural	Qt	12.13	11.95
88919	Oak, Golden	Qt	12.13	11.95
88917	Walnut, Black	Qt	12.13	11.95
88915	Walnut, Dark	Qt	12.13	11.95

KCDA No.	Description	U/M	1-11	12+
88927	Fruitwood	Gal	37.94	37.05
88901	Natural	Gal	37.94	37.05
88904	Medium	Gal	37.94	37.05
88920	Oak, Golden	Gal	37.94	37.05
88918	Black Walnut	Gal	37.94	37.05
88916	Walnut, Dark	Gal	37.94	37.05

TAPE

D) Duct Tape

Silver cloth back, 2"x60 yards. Qualifying Standard: Hystick.

KCDA No.	U/M	1-95	96+
88029	Ea	4.21	4.14

E) Safety Warning Tape

Yellow and black stripes, 2"x18 yards, used for lane marking. Pressure sensitive adhesive and plastic backing. Qualifying Standard: 3M.

KCDA No.	U/M	1-17	18+
88903	1/Roll	4.02	3.92

THINNERS

F) Brushing Lacquer Thinner

Qualifying Standard: Zimmerman.

KCDA No.	U/M	1-17	18+
88327	Gal	20.19	19.88
KCDA No.	U/M	1-7	8+
88328	5 Gal/Can	90.33	88.21

G) Shellac Thinner

Denatured alcohol solvent. Qualifying Standard: Sunnyside.

KCDA No.	U/M	1-23	24+
26040	Gal	20.45	20.13

2011 KCDA CATALOG

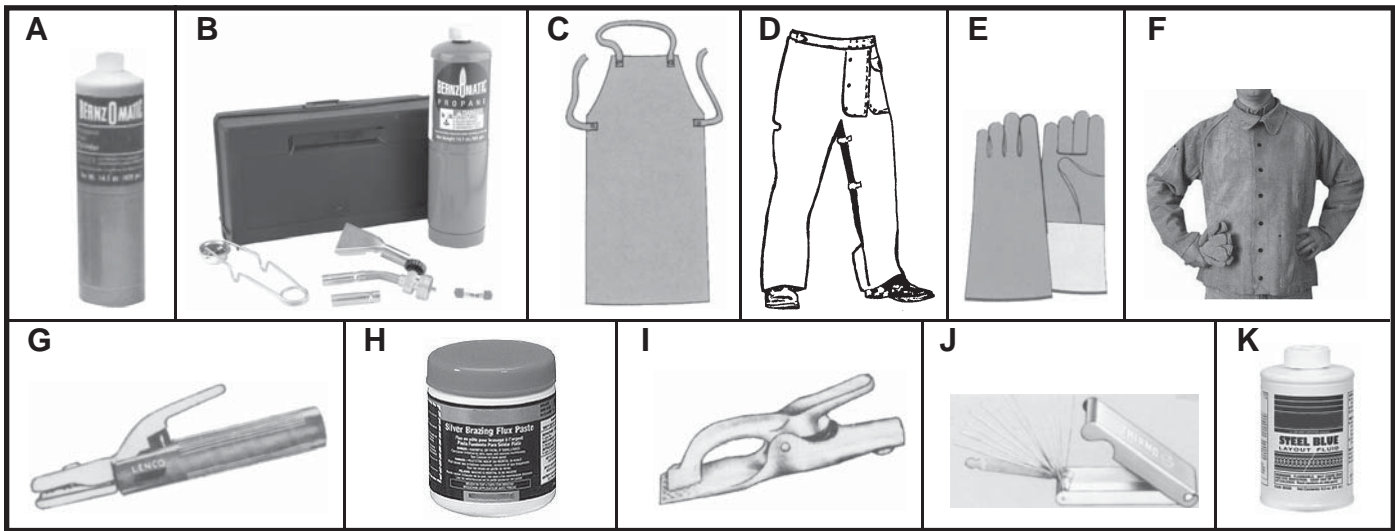

Spraying Lacquer Thinner
Qualifying Standard: Klean Strip.

KCDA No.	U/M	1-17	18+
88330	Gal	17.52	17.25
KCDA No.	U/M	1-7	8+
88331	5 Gal/Can	70.06	68.41

TORCH KITS & PROPANE

A) Propane Fuel Cylinder
14 ounce. Qualifying Standard: Bernz-o-Matic.

KCDA No.	U/M	1-23	24+
87533	Ea	5.57	5.48

B) Propane Torch Kit
Includes: cylinder, pencil head burner, utility burner and lighter.
Qualifying Standard: Bernz-o-Matic.

KCDA No.	U/M	1-5	6+
87532	Ea	74.08	72.33

TURPENTINE

Turpentine
Pure gum spirits. Qualifying Standard: Kleenstrip.

KCDA No.	U/M	1-23	24+
35100	1 Gal/Can	24.80	24.22

WELDING / CLOTHING

C) Welding Apron, Leather
Full length with bib. Qualifying Standard: Majestic.

KCDA No.	Size	U/M	1-11	12+
88980	24" x 36"	Ea	18.77	18.33
88982	24" x 48"	Ea	23.37	22.82

D) Welding Chaps, Leather
29" leg length. The medium fits 38" to 40" waist and the large fits 42" to 46" waist. Qualifying Standard: Tillman.

KCDA No.	Size	U/M	1-11	12+
88993	Medium	Pair	32.49	31.72
88994	Large	Pair	32.49	31.72

Welding Gloves, Cotton
Heat and flame resistant. Qualifying Standard: Tillman.

KCDA No.	U/M	1-11	12+
88987	Pair	1.47	1.43

E) Welding Gloves, Leather
Large, with gauntlet. Qualifying Standard: Tillman.

KCDA No.	U/M	1-11	12+
88986	Pair	2.61	2.55

F) Welding Jacket, Leather
Heat abrasion resistance, snap closure, golden brown leather. 30" long, full sleeve. Q-Line, 1 inside pocket, soapstone holder and welted shoulder seams. Qualifying Standard: Anchor-Tillman.

KCDA No.	Size	U/M	1-5	6+
88990	Large, 44 to 46	Ea	48.36	47.58

WELDING / ELECTRODE HOLDER

G) Electrode Holder
300 amp, 7/32 capacity. Qualifying Standard: Tweco.

KCDA No.	U/M	1-11	12+
87567	Ea	13.26	12.95

WELDING / FLUX

H) Flux
Qualifying Standard: Welco.

KCDA No.	Description	U/M	1-35	36+
88975	Brazing	1 Lb/Can	4.60	4.53

WELDING / GROUND CLAMP

I) Ground Clamp
300 amp. Qualifying Standard: Oki Bering.

KCDA No.	U/M	1-23	24+
87572	Ea	2.94	2.89

WELDING / GUN TIP CLEANERS

J) Tip Cleaners, Welding
Wires from #75 to #49. Qualifying Standard: Wypo.

KCDA No.	U/M	1-23	24+
87577	12/Set	2.07	2.04

WELDING / LAYOUT

K) Layout Fluid
Steel blue layout fluid is an extremely thin translucent film coating with uniform deep blue color that prevents glare and dries in 2-4 minutes. Remains flexible without cracking or chipping and enables you to scribe sharp, clear, precise lines. Resistant to synthetic coolants, soluble oils, kerosene, gasoline, toluene. Qualifying Standard: Dykem.

KCDA No.	Description	U/M	1-23	24+
88870	Brush in Cap	8 Oz/Can	8.59	8.45
88871	Aerosol Can	12 Oz/Can	13.14	12.94

2011 KCDA CATALOG

WELDING / RODS

Brazing Rods

Bronze-LF, bare.

KCDA No.	Diameter	U/M	1-3	4+
88970	3/32"	10 Lb/Pkg	79.94	78.06
88971	1/8"	10 Lb/Pkg	79.94	78.06

Electric Welding Rods

Arc, mild steel. Qualifying Standard: Lincoln, Hobart.

KCDA No.	Diameter	Number	U/M	1-5	6+
88941	1/8"	6011	50 Lb/Ctn	96.58	94.31
88948	1/8"	6013	50 Lb/Ctn	77.78	75.94

Oxyacetylene Welding Rods

36" long, mild steel, oxyacetylene. Qualifying Standard: Robinson Tech.

KCDA No.	Diameter	U/M	1-19	20+
88951	1/16"	10 Lb/Pkg	21.80	21.29
88950	3/32"	10 Lb/Pkg	20.91	20.42
88952	1/8"	10 Lb/Pkg	20.15	19.67
88953	5/32"	10 Lb/Pkg	19.64	19.17

WELDING / SPARK LIGHTER/FLINTS

A) Spark Lighter

Cup type. Qualifying Standard: Surelite.

KCDA No.	U/M	1-71	72+
87574	Ea	1.24	1.22

Spark Lighter Flints

Spark lighter flints. Qualifying Standard: Surelite.

KCDA No.	U/M	1-71	72+
87576	5/Pkg	0.70	0.69

WELDING / WIRE

MIG Aluminum Welding Wire

Metal inert gas (MIG.), .035. Qualifying Standard: Linde.

KCDA No.	U/M	1-59	60+
89980	1 Lb/Spl	5.96	5.86

MIG Steel Welding Wire

Steel metal inert gas (MIG.) Qualifying Standard: Linde.

KCDA No.	Size	U/M	1-9	10+
89988	.030 EZ Grind	10 Lb/Spl	12.88	12.57
89992	.035 x 29S	30 Lb/Spl	38.25	37.35

WIRE / MAGNETIC

B) Magnet Wire

Round, copper, solid. Single Insulated wire. Qualifying Standard: Paxton.

KCDA No.	Length	Gauge	U/M	1-23	24+
88910	203	18	1 Lb/Spl	21.61	21.10
88911	323	20	1 Lb/Spl	21.61	21.10
88912	514	22	1 Lb/Spl	22.82	22.29
88913	818	24	1 Lb/Spl	23.88	23.32
88914	1300	26	1 Lb/Spl	24.35	23.78

WIRE / UTILITY

C) Utility Wire

Black, annealed.

KCDA No.	Length	Gauge	U/M	1-23	24+
88906	480	16	5 Lb/Roll	25.82	25.21
88907	1550	20	5 Lb/Roll	34.14	33.34

WOOD / BAT STOCK

D) Baseball Bat Stock

Eastern Ash, 3"x3"x3' long. Qualifying Standard: Paxton.

KCDA No.	U/M	1-11	12+
89003	Pce	28.43	27.76

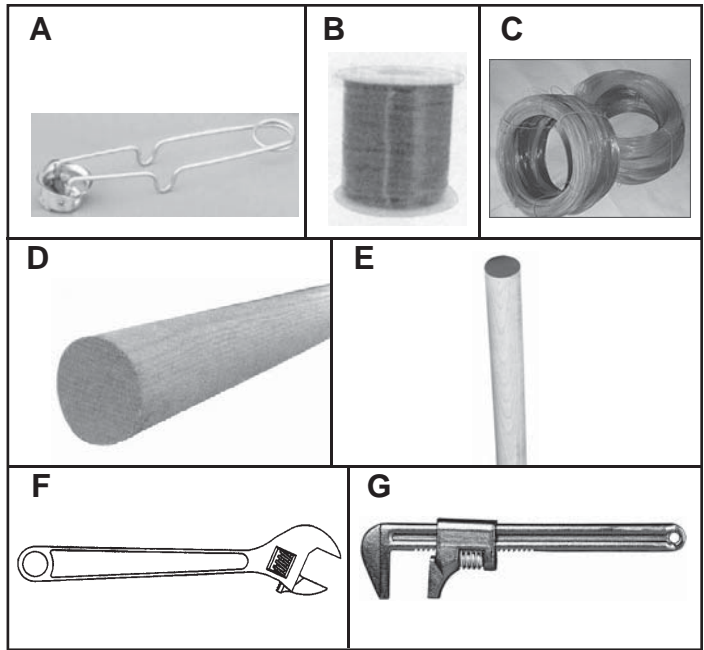

WOOD / DOWEL

Hardwood Dowels

4 foot lengths.

KCDA No.	Size	U/M	1-3	4+
89004	1/8" dia. x 4 ft.	100/Bndl	13.12	12.81
89005	3/16" dia. x 4 ft.	100/Bndl	14.99	14.64
89006	1/4" dia. x 4 ft.	100/Bndl	22.04	21.53
89007	3/8" dia. x 4 ft.	100/Bndl	41.50	40.52
89008	1/2" dia. x 4ft.	50/Bndl	35.70	34.86
89010	3/4" dia. x 4 ft.	25/Bndl	42.39	41.40
89012	1" dia. x 4 ft.	25/Bndl	83.86	81.88

E) Hardwood Dowels

3 foot lengths.

KCDA No.	Size/Diameter	U/M	1-3	4+
89002	1/8" dia. x 3 ft.	100/Bndl	10.17	9.94
89014	3/16" dia. x 3 ft.	100/Bndl	12.14	11.85
89015	1/4" dia. x 3 ft.	100/Bndl	15.17	14.82
89016	3/8" dia. x 3 ft.	100/Bndl	29.54	28.85
89017	1/2" dia. x 3 ft.	50/Bndl	25.26	24.66
89018	5/8" dia. x 3 ft.	25/Bndl	20.81	20.32
89019	3/4" dia. x 3 ft.	25/Bndl	30.22	29.51
89021	1" dia. x 3 ft.	10/Bndl	23.08	22.53
89022	1-1/4" dia. x 3 ft.	8/Bndl	31.42	30.68

WRENCHES / ADJUSTABLE

F) Adjustable Wrenches

Black oxide finish. Qualifying Standard: Stanley.

KCDA No.	Size	U/M	1-23	24+
87584	6"	Ea	4.68	4.57
87585	8"	Ea	5.88	5.74
87586	10"	Ea	7.70	7.52
87587	12"	Ea	9.29	9.08

WRENCHES / AUTO

G) Auto Wrench

Chrome-plated, carded, non-cushion grip. 11" long with a 3" jaw opening. Qualifying Standard: Crescent.

KCDA No.	U/M	1-23	24+
87616	Ea	38.57	37.66

2011 KCDA CATALOG

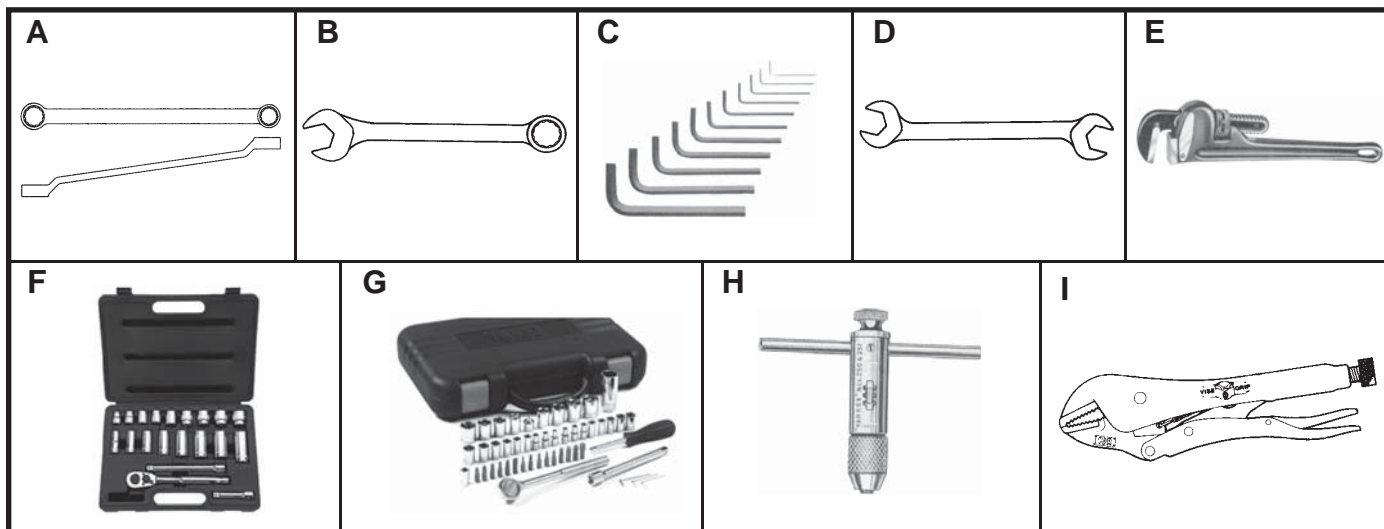

WRENCHES / BOX

A) Box Wrenches

Offset box end wrenches Double end. Qualifying Standard: Urrea.

KCDA No.	Size	U/M	1-23	24+
87592	3/8" to 7/16"	Ea	6.15	6.06

WRENCHES / COMBINATION

Combination Wrench Set

18 piece metric set includes 7mm thru 27mm size. Qualifying Standard: Craftsman.

KCDA No.	U/M	1-7	8+
87599	1/Set	122.97	120.99

B) Combination Wrenches

Qualifying Standard: KR Tools.

KCDA No.	Size	U/M	1-23	24+
87600	1/2"	Ea	3.86	3.80
87604	3/4"	Ea	6.16	6.07
87602	5/8"	Ea	4.64	4.56
87606	7/8"	Ea	7.52	7.35
87601	9/16"	Ea	10.02	9.87
87603	11/16"	Ea	5.26	5.18
87605	13/16"	Ea	6.73	6.57

WRENCHES / HEX KEY

C) Hex Key Wrench Set

11 sizes. Qualifying Standard: Great Neck.

KCDA No.	U/M	1-23	24+
87588	1/Set	3.82	3.76

WRENCHES / OPEN END

D) Open End Wrenches

Open end 15 degrees. Qualifying Standard: Urrea.

KCDA No.	Size	U/M	1-23	24+
87610	1/4" to 5/16"	Ea	2.58	2.54
87611	3/8" to 7/16"	Ea	2.71	2.66
87612	1/2" to 9/16"	Ea	3.22	3.17
87613	5/8" to 3/4"	Ea	4.45	4.39

WRENCHES / PIPE

E) Pipe Wrenches

Qualifying Standard: Stanley.

KCDA No.	Size	U/M	1-23	24+
87618	18"	Ea	13.26	12.95

KCDA No.	Size	U/M	1-11	12+
87619	24"	Ea	23.46	22.91

WRENCHES / SOCKET

F) Drive Socket Set, 20 Piece

Drive socket set contains:

- 3/8" Drive Sockets 12 Pt (3/8", 7/16", 1/2", 9/16", 5/8", 11/16", 3/4", 13/16", 7/8").
- 3/8" Drive Deep Sockets 12 Pt (3/8", 7/16", 1/2", 9/16", 5/8", 11/16", 3/4", 13/16").
- 3/8" Drive Extensions (3" & 6").
- 3/8" Pear Head Ratchet.
- Blow mold case. Qualifying Standard: Stanley.

KCDA No.	U/M	1-5	6+
87635	Ea	44.75	43.70

G) Drive Socket Set, 50 Piece

Drive socket set contains:

- 6 pt. 1/4" SAE Sockets: 3/16", 7/32", 1/4", 9/32", 5/16", 11/32", 3/8" & 7/16".
- 6 pt. 1/4" Metric Sockets: 4mm to 12mm.
- 6 pt. 3/8" SAE Sockets: 9/16", 5/8", 11/16" & 3/4".
- 6 pt. 3/8" Metric Sockets: 13mm, 14mm, 15mm & 17mm.
- 1/4" Spinner Handle.
- 1/4" Screwdriver Bit Adapter.
- Bits: 3 Slotted; 3 Phillip; 6 Hex; 3 Star.
- 3 Hex Keys.
- 13/16" Spark Plug Socket.
- 6" Extension Bar.
- Reversible Ratchet Handle.
- 3/8"-1/4" Adapter.
- Carrying case. Qualifying Standard: Pony

KCDA No.	U/M	1-5	6+
87631	Ea	46.67	45.57

WRENCHES / TAP

H) Tap Wrench

T-handle, ratchet, 5/16" capacity. Qualifying Standard: Stanley.

KCDA No.	U/M	1-23	24+
87626	Ea	20.88	20.39

WRENCHES / VISE GRIPS

I) Vise Grip Wrenches

Qualifying Standard: Vicegrip.

KCDA No.	Description	U/M	1-23	24+
87629	7" Curved Jaw	Ea	6.51	6.41
87627	7" Straight Jaw	Ea	6.32	6.22
87630	10" Curved Jaw	Ea	7.86	7.74
87628	10" Straight Jaw	Ea	7.86	7.74