

INVITATION FOR BIDS
Bid #26-374, Bleachers, Auditorium Seating, and Other Equipment

Attachment A1 – Cover Page Direct Ship

Due June 4, 2026, On or before 2:00 p.m., PST

King County Directors' Association (KCDA) is a purchasing cooperative owned by the school districts of Washington State and is located in Kent, Washington. KCDA's membership is made up of, but not restricted to, public school districts, private schools, municipalities, political subdivisions and other public agencies primarily located in Washington, Oregon, Idaho, Alaska, and Montana. Representing over 1 million students and over 5,000 ship to locations, KCDA purchases approximately \$190 million worth of products, equipment and services on behalf of the membership.

The KCDA Purchasing Cooperative (hereinafter "KCDA") requests bids from manufacturers and/or dealers who can offer Bleachers, Auditorium Seating, and other Equipment to its member agencies.

Total estimated value of this contract is approximately \$7 million to \$8 million annually.

Each response is to be filed in a separate envelope and marked with the appropriate IFB number, name, day and time of opening. All bids must be at KCDA's office on or before the time shown above or they will not be accepted nor considered. Responses sent via email, faxed, or "postage due" will not be accepted. Responses sent via Federal Express, Express Mail or other overnight delivery services must be sent to: KCDA, 18639 80th Ave S, Kent WA 98032 and clearly marked with the IFB number and name, Attn: Purchasing Department.

ATTN: Purchasing Department
IFB# 26-374, Bleachers, Auditorium Seating, and Other Equipment
KCDA
18639 – 80th Ave S
Kent, WA 98032

The vendor has full responsibility to ensure the proposal arrives to the Purchasing Office by the due date and time. KCDA assumes no responsibility for delays caused by the U.S. Post Office or any other delivery service. Postmarking by the due date will not substitute for actual receipt of response by the date due. Proposals arriving after the deadline may be returned unopened to the vendor, or may simply be declared non-responsive and not subject to evaluation, at the sole determination of KCDA. All questions pertaining to this bid shall be entered in the "Questions" section of Public Purchase. No emails or phone inquiries will be accepted.

Electronic copies of this IFB are available via KCDA's website at www.kcda.org. Click on Contracts & Bids / Vendor Bids. Materials can also be downloaded online via Public Purchase www.publicpurchase.com. If you have trouble opening the document, please contact the Contract Specialist named below.

Karl Durham, Contract & Procurement Specialist
kdurham@kcda.org
(425)251-8115 X 131

Published in the Daily Journal of Commerce-Seattle
and the Daily Journal of Commerce-Oregon
April 24, 2026 and May 1, 2026

**KING COUNTY DIRECTORS' ASSOCIATION
INVITATION FOR BIDS
Attachment A2 – T&C Direct Ship – Bleachers, Auditorium Seating, other Equipment**

NOTE: THERE ARE NO FEES ASSOCIATED WITH KCDA BIDS WHEN USING PUBLIC PURCHASE

INVITATION FOR BIDS INDEX

- I. INTRODUCTION
 - A. KCDA Membership
 - B. Interpretation of Bid Documents
 - C. Exceptions
 - D. Contract Default
 - E. Bidder Responsibility
 - F. Bidder Financial Responsibility
 - G. Minority and Women Owned Businesses

- II. GENERAL PROVISIONS
 - A. Bid Opening
 - B. Modifications
 - C. Quality Standards
 - D. Rejection of Any or All Responses
 - E. Binding Contract
 - F. Estimated Quantities
 - G. Contract Period
 - H. Ordering Schedule
 - I. Extended Contract Period
 - J. Requested Samples
 - K. Disposal of Samples
 - L. Anti-Discrimination Clause
 - M. Indemnification
 - N. Patent Indemnification
 - O. Safety Requirements
 - P. Risk of Loss
 - Q. Rejection
 - R. Shipment Identification
 - S. No Bid Response
 - T. Bid Awards
 - U. Termination
 - V. Reciprocity
 - W. Force Majeure

- III. PREPARATION OF BID
 - A. Submittal of Bid Document
 - B. Signatures
 - C. Questions/Addendums
 - D. F.O.B. Shipments
 - E. Product Identification

- F. Quantity per Unit of Measure
 - G. Alternate Proposal
 - H. Errors/Corrections
 - I. Invoicing
 - J. Cash Discounts/Invoice Payment Terms
 - K. Washington State Sales Tax
- IV. PRODUCT ACCEPTANCE
- A. General Policy
- V. BID PROTESTS
- A. Who may protest
 - B. What can be protested
 - C. How to file a protest
 - D. When to protest
 - E. Where to file a protest
 - F. After a protest is filed
- VI. PRODUCT TOXICITY REPORTS
- A. Hazardous Chemical Communication
- VII. SPECIAL NOTATIONS

ATTACHMENT A - Certification Regarding Debarment, Suspension, Ineligibility, and Voluntary Exclusion
ATTACHMENT B - Terms by Manufacturer
ATTACHMENT C - Special Provisions

I. INTRODUCTION

A. KCDA MEMBERSHIP

KCDA is a purchasing cooperative owned by 294 public school districts in the state of Washington and is located in Kent, Washington. KCDA's membership is made up of, but not restricted to public school districts, private schools, municipalities, political subdivisions and other public agencies located in but not limited to Washington, Oregon, Idaho, Alaska, and Montana. Representing over 1 million students and over 5,000 ship to locations, KCDA purchases approximately \$190 million worth of products, equipment and services on behalf of the membership.

All school districts and other public agencies who are or may become members of the KCDA Purchasing Cooperative may participate in the contract awarded as a result of this bid. A complete list of all school districts and other public agencies that are members of the KCDA Purchasing Cooperative is available on our web site at www.kcda.org.

Restrictions of merchandise or services to any locale of KCDA membership must be clearly noted in a bid response.

B. INTERPRETATION OF BID DOCUMENTS

Any person contemplating submitting a bid for the proposed contract that is in doubt as to the true meaning of any part of the bid documents, or finds discrepancies in or omissions from the bid documents, shall submit to KCDA a written request for an interpretation or correction thereof. Such request shall be submitted and received not later than 10 days prior to the date specified for receipt of bid responses. Any interpretation or correction of the bid documents will be made in writing by addendum duly issued to all bidders. KCDA will not be responsible for any other explanation or interpretation of the bid documents.

C. EXCEPTIONS

Any exceptions to the terms and provisions of this invitation for bids shall be made by signed and dated attachment to the bid response. Do not add to, delete from, or amend in any manner the bid form. Exceptions pertaining to payment or delivery terms must be noted within Attachment B. All noted exceptions are subject to approval and acceptance by KCDA.

D. CONTRACT DEFAULT

Your bid is subject to all terms and conditions as herein established in this bid request form and include price, quality and delivery. Subsequent failure to provide items bid in accordance to the purchase order and bid delivery schedule will constitute contract default, and, after due written notification, allows the Purchasing Department to declare the contract void and to purchase the merchandise on the open market. Any additional costs to procure and distribute replacement product will be charged to the bidder.

E. BIDDER RESPONSIBILITY

All bidders shall thoroughly examine and be familiar with the bid documents including all exhibits and attachments. The failure or omission of a bidder to receive or examine any form, instruments, addendum, or other document shall in no way relieve any bidder from obligations with respect to your bid or to the contract. The submission of a bid shall be taken as prima facie evidence of compliance with this section.

F. BIDDER FINANCIAL RESPONSIBILITY

KCDA has the right to request financial information from any bidder to evaluate the bidder's ability to meet the terms and conditions of any and all contracts that may be established by acceptance of the offer contained in the bid. Additional confirmation from the bidder's supplier(s) that the delivery terms of the contract will be met may be required. KCDA reserves the right to reject any or all bids and/or bidders unable to prove they are financially able to provide the quantity of merchandise they have offered in response to this bid invitation.

G. MINORITY AND WOMEN OWNED BUSINESSES

KCDA encourages all minority and women owned businesses to participate in the bid process. Washington State law does not allow KCDA to provide any financial advantage for minority and women owned businesses who participate, however, KCDA believes that a diverse range of suppliers benefits all.

II. GENERAL PROVISIONS

A. BID OPENING

All bids submitted for supplies and/or services will be opened in public at the time, date and place, and in the manner herein specified, and all bidders are invited to be present at the opening of such bids. A final recap will be available from KCDA after bid awards are made. Under no circumstances will a bid be

considered if filed after the hour specified in the invitation for bids. To be considered for award, a bid response must be submitted according to the instructions and prior to the date and time indicated within. The times listed in any referenced schedule are Pacific Standard Time.

KCDA will not accept bids that are sent via fax or email.

The KCDA address is:

King County Director's Association
Purchasing Department
18639 80th Ave S
Kent, WA 98032

B. MODIFICATIONS/WITHDRAWAL OF BID

Bids may be modified or withdrawn by written notice received prior to the exact hour and date specified for receipt of bids. Bids may also be modified or withdrawn in person by an authorized representative, who must sign a receipt for this action. Returned and/or unsubmitted bids shall become the responsibility of the bidder. Bids that are not resubmitted on or before the exact time of the opening may not be considered for award.

C. QUALITY STANDARDS

Whenever an item in this invitation for bid is described using a manufacturer's name, brand or catalog number, it shall be construed solely for the purpose of indicating the standards of quality. Brands of equal quality shall be considered, except where otherwise stated, provided the bidder specifies the brand, model and number on which their bid is submitted and submits samples, specifications and other information necessary to properly evaluate the bid. Any bid containing a brand which is not of equal quality at the sole discretion of KCDA, shall not be considered. KCDA will accept bids on new product only. Merchandise that has been refurbished or has been in storage for a long period of time is unacceptable.

D. REJECTION OF ANY OR ALL RESPONSES

KCDA reserves the right to accept or reject any or all bids and to waive informalities or irregularities in any bid or in the bidding process.

E. BINDING CONTRACT

It is understood that the offer represented by a bidder and an award made by the KCDA Board of Directors to the successful bidder, forms a binding contract. KCDA, under certain circumstances, will allow the assignment of contracts; however, no assignment can occur to another entity without written agreement from KCDA.

F. ESTIMATED QUANTITIES

Quantities, if shown on the bid forms, are estimated requirements of the members for whom KCDA acts as purchasing department based on historical ordering information. Such quantities represent the total quantity the cooperative anticipates purchasing over the life of the contract period. KCDA reserves the right to order more or less than the quantities stated in the bid. Any minimum order requirements or ordering restrictions should be so indicated as part of the bid response and will be subject to bid evaluation. Quantities ordered are based on actual requirements and the successful bidder will fulfill that requirement regardless of the manufacturer's policies regarding order completion.

G. CONTRACT PERIOD

Following an award, a contract would be issued as an annual contract from the date of KCDA Board acceptance, or as noted under Special Provisions. After the initial period, there is a possibility of three (3) renewals for the duration of one (1) year each. Pricing is firm for the first/initial period.

H. ORDERING SCHEDULE

Based upon accepted minimum order requirements set by the successful bidder, KCDA or KCDA members may submit orders once a contract has been established by the KCDA Board of Directors. KCDA reserves the right to place orders anytime, for any amount, during the contract period based upon any accepted minimum quantities and time restrictions set forth by the successful bidder attached to their bid response. Quantities and delivery dates listed in this bid are presented as a guide to the bidder, but will not be binding or limiting to the KCDA and its members.

I. EXTENDED CONTRACT PERIOD

By mutual written agreement of KCDA Board of Directors and the successful bidder, the initial contract period may be extended for additional periods, not to exceed extensions of 3 years total beyond the initial contract. Such extensions shall be at the awarded price in effect at the time and under the same terms and conditions as the original contract unless otherwise allowed under terms of the contract. Requests for extension shall be submitted to KCDA a minimum of 30 days prior to expiration of the existing contract term.

J. REQUESTED SAMPLES

It is the bidder's responsibility to provide samples, **if requested by KCDA**, for a bid response to be considered. Submit the samples to King County Directors' Association, 18639 80th Ave. S., Kent, Washington, 98032 **when requested**. All requested samples must be labeled with the bid number, KCDA's item number (as applicable) and bidder's name, and be submitted no later than seven (7) working days after request.

DO NOT ENCLOSE YOUR BID WITH THE SAMPLES.

K. DISPOSAL OF SAMPLES

Bid samples not picked up within 30 days after the bid award date shall become the property of the King County Directors' Association and shall be disposed of by distribution to the member school districts or by donation as deemed appropriate by KCDA.

L. KCDA NON-DISCRIMINATION STATEMENT

Bidders who desire to provide KCDA with equipment, supplies and/or professional services must comply with the following Non-Discrimination requirements. During the performance of this contract, the Bidder agrees as follows:

Bidder will comply with all Local, State and Federal Laws prohibiting discrimination with regard to race, creed, color, national origin, sex, marital status, age or the presence of any sensory, mental or physical handicap.

The Bidder will not discriminate against any employees or applicant for employment because of race, creed, color, national origin, sex, marital status, age or the presence of any sensory, mental or physical handicap.

The Bidder will, in all solicitations or advertisements for employees placed by or on behalf of the Bidder, state that all qualified applicants will receive consideration for employment without regard to race, creed, color, national origin, sex, marital status, age or the presence of any sensory, mental or physical handicap.

Any Bidder who is in violation of these requirements, or an applicable nondiscrimination program shall be barred forthwith from receiving bid awards or any purchase orders from KCDA.

M. INDEMNIFICATION

The Vendor agrees to defend, indemnify and hold harmless KCDA and the member agency, and their respective officers, officials, employees and volunteers from any and all claims, injuries, damages, losses or suits including attorney fees arising out of or resulting from the acts, errors or omissions in performance of this Agreement, except for injuries and damages caused by the sole negligence of KCDA or the member agency. Should a court of competent jurisdiction determine that this Agreement is subject to RCW 4.24.115, then, in the event of liability for damages arising out of bodily injury to persons or damages to property caused by or resulting from the concurrent negligence of the Vendor, KCDA or the member agency and their respective officers, officials, employees, and volunteers, the Vendor's liability, including the duty and cost to defend, hereunder shall be only to the extent of the Vendor's negligence. It is further specifically and expressly understood that the indemnification provided herein constitutes the Vendor's waiver of immunity under Industrial Insurance, Title 51 RCW, solely for the purpose of this indemnification. Use of this contract certifies that the waiver of immunity specified by this provision was mutually negotiated by the parties. The provisions of this section shall survive the expiration or termination of the Agreement.

N. PATENT INDEMNIFICATION

By accepting this order, Bidder agrees to save and hold harmless KCDA, its successors, assigns, customers and the users of its products from any liability, loss, damage, judgments, or awards, including costs and expenses arising out of any actions, claims, or proceedings for infringement of (a) any United States Letters Patent purporting to cover the material to be delivered to Buyer under this order, or its normal intended use and (b) any trademarks appearing with the material on delivery to KCDA; and further, Bidder agrees to defend KCDA, its successors, assigns, customers and the users of its products at Bidder's expense in all such actions, claims, or proceedings, provided that KCDA shall give Bidder prompt notice in writing of all such actions, claims, and proceedings, as well as notice of infringement and threats of suit for infringement.

O. SAFETY REQUIREMENTS

All items furnished under this bid, where applicable, must comply with all OSHA, WISHA, UL Approval, including but not limited to chapter 296-46B of the Washington Administrative Code and any other safety requirements imposed by KCDA, State or Federal agencies. Bidder further agrees to indemnify and hold KCDA harmless from all damages assessed against KCDA as a result of Bidder's failure to comply with the acts and the standards issued thereunder and for the failure of the items furnished under this order to so comply.

P. RISK OF LOSS

Regardless of F.O.B. point, Bidder agrees to handle all claims and bear all risk of loss, injury, or destruction of goods and materials ordered herein which occur prior to delivery, and such loss, injury, or destruction shall not release Bidder from any obligation hereunder.

Q. REJECTION

All goods or materials purchased herein are subject to approval by KCDA or the KCDA member. Any rejection of goods or materials resulting from non-conformity to the terms, conditions and specifications of an order, whether held by KCDA, KCDA member, or returned will be at Bidder's risk and expense.

R. SHIPMENT IDENTIFICATION

All invoices, packing lists, packages, shipping notices, instructions, correspondence and all other written documents affecting any KCDA order shall contain the applicable purchase order number. A packing list must be provided with every shipment being made to KCDA indicating all the products shipped and back ordered; also, every carton shipped pursuant to this order must be marked with the contents therein.

S. NO BID RESPONSE

If no offer is to be submitted at this time, do not return this bid. A letter should be forwarded to KCDA advising whether future bids of this type are desired. Failure of the recipient to notify KCDA of your intentions may result in removal of your name from the bidder's list.

T. BID AWARDS

Following evaluation, bids recommended for award will be awarded by the KCDA Board of Directors to the lowest responsible bidder meeting specifications and price as primary factors. KCDA reserves the right to award items in groups for ordering efficiencies, to meet minimum requirements (if accepted), to make multiple awards, or to reject any and all bids or portions thereof, to waive any minor irregularities in the bid process, or to make no awards, if in its sole judgment the best interests of KCDA and its members will not be served.

U. TERMINATION

Termination for Convenience: KCDA may terminate this contract, in whole or in part, at any time and for any reason by giving thirty (30) calendar days written termination notice to Vendor. Termination charges shall not apply unless both parties subsequently agree upon them. Where termination charges are applicable, both parties agree to negotiate in good faith and to limit the extent of negotiations to valid documented expenses incurred by Vendor prior to date of termination. KCDA will not be responsible for stock that the Vendor has on hand that has not been requested via a purchase order. Should the parties not agree to a satisfactory settlement, the matter may be subjected to mediation and/or legal proceedings.

V. RECIPROCITY

Where allowed by law, KCDA may review responses from bidders outside the State of Washington to see if those bidders are from states that use restrictions against companies from the State of Washington when they respond to public bids. KCDA may use this information in making bid awards when multiple bidders appear to have submitted the same pricing, terms and conditions on a particular bid item or items.

W. FORCE MAJEURE

Except for payments of sums due, neither party shall be liable to the other, nor be deemed in default under this contract, if and to the extent that such party's performance of this contract is prevented by reason of force majeure. The term "force majeure" means an occurrence that is beyond the control or responsibility of the party affected and occurs without its fault or negligence, including, but not limited to the following: acts of God; acts of the public enemy; war; riots; strikes; industry-wide labor disputes; civil disorders; fire; flood; snow; earthquakes; tornadoes or violent winds; hail storms; lockouts;

injunctions-intervention-acts, or failures or refusals to act by government authority; and other similar occurrences beyond the control or responsibility of the party declaring force majeure, which such party is unable to prevent by exercising reasonable diligence. The force majeure shall be deemed to commence when the party declaring it notifies the other party of the existence of the force majeure, and shall be deemed to continue as long as the results or effects of the force majeure prevent the party from resuming performance in accordance with the contract. The party receiving the notice of force majeure may contest the declaration of a force majeure. Force majeure shall not include late deliveries of equipment or materials caused by congestion at a manufacturer's plant or elsewhere, an oversold condition of the market, inefficiencies, internal labor disputes, or similar occurrences. If either party is delayed at any time by force majeure, the delayed party shall notify the other party in writing of such delay within forty-eight (48) hours.

III. PREPARATION OF BID

A. SUBMITTAL OF BID RESPONSE

Submission of a response as designated in the bid instructions signifies that bidder will be bound to the terms and conditions of this bid unless an exception is made part of the submission and accepted by KCDA.

Bidder must submit the Certification Regarding Debarment, Suspension, Ineligibility and Voluntary Exclusion form, included as Attachment A. Bids received without this form may be considered non-responsive.

B. SIGNATURE

Bid responses are required to include the firm name, address, telephone number, contact name and authorized signature, signed in longhand by the person duly authorized to sign bid documents identified in the solicitation. Every attempt will be made to answer all questions. Where a response or addendum cannot be obtained prior to the bid opening, it is understood that the Bidder will assume the more stringent of requirements.

C. QUESTIONS/ADDENDUMS

All questions must be submitted in writing to the KCDA Purchasing Agent.

D. F.O.B. SHIPMENTS

Prices must be quoted in the UNIT SPECIFIED, PACKAGING INCLUDED and except for cash discount percentages, quoted NET, F.O.B. THE DELIVERY POINT specified in this bid, including the unloading of the merchandise. KCDA typically redistributes products to its members unless designated or requested as a direct ship method. All merchandise shipped to KCDA must be in packaging that can be reshipped, via common carrier, without damage. Any damage incurred due to insufficient packaging will be the responsibility of the supplier.

No charges will be allowed for special handling, packing, wrapping, bags, containers, reels, etc.

E. PRODUCT IDENTIFICATION

All bid responses must confirm the manufacturer number, brand name or grade specified in the bid invitation and such identification shall be binding on the bidder. Bidders must insert the manufacturer number, brand name, grade and any other information necessary to clearly and properly describe and identify the articles they propose to furnish. If necessary attach additional documentation for this purpose. Alternates should be noted as an "alternate item" and properly identified with brand,

manufacturer number, etc. The bidder is not to alter the grade, brand, manufacturer number or description as given in the bid invitation. Questions on how to properly submit an alternate item must be directed to the named Purchasing Agent responsible for this bid.

F. QUANTITY PER UNIT OF MEASURE

Where applicable, if the quantity or volume per unit differs from that specified in the bid invitation for any particular item, it is mandatory to note such difference in the bid response. Any bid submitted not showing the quantity per unit of measure will be construed to mean the bidder will furnish the unit of measure as specified in the bid invitation and such interpretation shall be binding on the bidder. If the bidder provides a unit of measure different from the KCDA requirement, it will be construed as an alternate item. Any merchandise subsequently received in other than KCDA units must be repackaged to correct units. Repackaging is the responsibility of the bidder who has entered into the contract. Payment will not be tendered until the merchandise has been packaged to KCDA units. If necessary, KCDA reserves the right to repackage merchandise to KCDA units and charge the bidder for all fair and reasonable associated costs. KCDA requires that upon award, the successful bidder establish a factory pack unit and ship in that unit for the duration of the contract.

G. ALTERNATE SPECIFICATIONS

An alternate specification is where the bidder is offering a product or service significantly different than outlined in the bid request, and typically applies to items listed as “No Substitute”.

For alternate specifications to be considered, a request must be submitted to KCDA 15 working days prior to the bid opening. If accepted by KCDA, a clarification will be issued to all bidders on a bid addendum. Alternate specifications may be accepted if they meet the conditions above and they are deemed to be in the best interest of KCDA and their member agencies.

H. ERRORS/CORRECTIONS

Any erasures, interlineations or other correction in the bid must be initialed by the person(s) signing the bid. Corrections must be provided within the terms of the vendor response and accepted by KCDA.

I. INVOICING

It is understood that invoices issued by the manufacturer/dealer will reflect the shipping date of materials. It is also understood that actual delivery and install or training at the end user location may be delayed from the date of shipment. Subsequently, payment will be made after satisfactory delivery and acceptance by the end user of any quantity of merchandise shipped and/or installed. Advance discussion regarding payment terms on specific projects are recommended where this may occur. Where KCDA participates in the invoicing process, KCDA reserves the right to withhold payment to a vendor on a project until such time payment from the customer has been received.

Invoices enclosed with merchandise will not be accepted. Invoices shall contain the following information: purchase order number, item number, quantity ordered, quantity shipped, unit price, extension, terms and sales tax. Payments will be made on original invoicing only.

J. CASH DISCOUNTS/INVOICE PAYMENT TERMS

KCDA payment terms are Net-30 days. Cash discounts are encouraged and cash discount percent and terms may be entered on Attachment B. KCDA will subtract cash discount percentages where it is

deemed probable that KCDA will be able to take advantage of the offered discounts. KCDA will accept terms for as few as 15 days.

KCDA is required, by law, to process invoice payments through the King County Treasurer. Payment warrants can be issued weekly. The first day for start of terms shall begin with acceptance of delivery or installation by the end user or receipt of invoice, whichever is later. Invoices with discounts between 15 and 30 days will be paid within terms and net 30-day invoices will be paid on the first pay date after 30 days.

K. WASHINGTON STATE SALES TAX

Washington State sales taxes are not to be included in any items as part of the bid response, but will be added at the time of invoicing. All other taxes, including but not limited to any excise or business and occupation tax must be included in your bid price. The only taxes KCDA will pay upon invoice are the Washington State Sales tax.

IV. PRODUCT ACCEPTANCE

A. GENERAL POLICY

The Purchasing Department shall have the right to reject any and all articles that are not in strict conformity with requirements and specifications of the bid and the approved samples submitted by the bidder. The bidder must replace all rejected articles promptly with articles of quality equal to the specifications or samples submitted and remove rejected articles at his own expense. In the event of failure on the part of the bidder to promptly replace rejected articles, the Purchasing Department reserves the right to purchase same on the open market or of declaring the contract void. Any additional costs incurred to procure and distribute replacement product will be charged to the bidder.

V. BID PROTESTS

A. WHO MAY PROTEST

Only actual or potential bidders with a direct economic interest in the outcome may file a bid protest.

B. WHAT CAN BE PROTESTED

Acceptance or rejection of a bid proposal, award or proposed award of a bid, allegedly restrictive specifications, omission of a required provision, ambiguous or indefinite evaluation factors are all factors that can be protested.

C. HOW TO FILE A PROTEST

Protests may be filed with either the KCDA purchasing agent who issued the bid or with the KCDA purchasing manager.

Protests should include the following information:

- 1) Include the name, street address, email address, telephone and fax numbers of the protestor or their representative.
- 2) Be signed by the protestor or its representative.
- 3) Identify the solicitation or bid contract number.
- 4) Set forth a detailed statement of the legal and factual grounds of protest, including copies of relevant documents.
- 5) Set forth all information establishing that the protestor is an interested party for the purpose of filing a protest.

- 6) Set forth all information establishing the timeliness of the protest.
- 7) Specifically request a ruling by the KCDA purchasing manager.
- 8) State the form of relief requested.

Appeals of protest ruling must be made in the following order:

- 1) KCDA Purchasing Manager,
- 2) KCDA Executive Director
- 3) KCDA Board of Directors.

D. WHEN TO PROTEST

Protests alleging improprieties in a solicitation must be filed before the bid opening time and date if the improprieties were apparent prior to that time. A solicitation defect that was not apparent before that time must be protested not later than 2 business days after the defect became apparent.

E. WHERE TO FILE A PROTEST

Protests must be sent to:

KCDA Purchasing Cooperative
PO Box 5550
Kent, WA 98064-5550

F. AFTER A PROTEST IS FILED

Upon receipt of a protest, KCDA will acknowledge receipt of the protest in writing either by mail, fax or email. The only time an acknowledgement is not sent will be if the protest is summarily dismissed. Protestors may be contacted for a meeting to review the protest. Within 10 days KCDA will make a decision as to the merits of the protest and notify the protestor of the decision and any remedies in the matter.

VI. PRODUCT TOXICITY REPORTS

A. HAZARDOUS CHEMICAL COMMUNICATION

In order to comply with the revised OSHA and Globally Harmonized System of Classification and Labelling of Chemicals (GHS), all bidders offering products on this bid that contain any toxic chemicals that may be harmful to the end user must provide a Safety Data Sheet (SDS). Awarded vendors are to use the list of awarded items presented at time of contract signing and submit an SDS sheet for each item, referencing the KCDA item number, within 30 days of the contract start date, to kcdasds@kcda.org.

Any hazardous material tax must be included in the price of the product bid. KCDA will not be held responsible for any additional taxes (other than Washington State Sales Tax) and will not pay them if noted as a separate line item on invoices.

VII. SPECIAL NOTATIONS

ATTACHMENT A - Certification Regarding Debarment, Suspension, Ineligibility, and Voluntary Exclusion

ATTACHMENT B - Terms by Manufacturer

ATTACHMENT C - Special Provisions



**INVITATION FOR BIDS
BID #26-374, Bleachers, Auditorium Seating, and Other Equipment**

BID DUE DATE: June 4, 2026, On or Before 2:00 PM PST

Attachment A –

Certification Regarding Debarment, Suspension, Ineligibility and Voluntary Exclusion

In submitting the proposal to provide products and/or services as outlined in the bid specifications, we hereby certify that we have not been suspended or in any way excluded from Federal procurement actions by any Federal agency. We fully understand that, if information contrary to this certification subsequently becomes available, such evidence may be grounds for non-award or nullification of a bid contract.

This certification is required by the regulations implementing Executive Order 12549, Debarment and Suspension, Participant’s Responsibilities.

Signed: _____
Title: _____
Firm: _____
Address: _____
City, State, Zip: _____
Date: _____
Email _____

Note: Electronic acceptance of these terms and conditions signifies compliance with above statement. (Line item Whse bids)



ATTACHMENT B
 Terms by Manufacturer
 Bid #26-374, Bleachers,
 Auditorium Seating, and Other
 Equipment

Bid Due Date: June 4, 2026, On or Before 2:00 PM PST

Bidder Name:		Address:			
Phone:	Fax:	City, State, Zip:			
TERMS BY MANUFACTURER: Please provide the minimum order required per manufacturer and lead times.		SPECIFIC DISCOUNTS: Please provide quoted discounts from the manufacturer's current list prices. It is the bidders responsibility to submit updated price lists during the contract year, when the contract allows, otherwise discounts will be taken from the most current on file. The manufacturer must already be present in this bid to be considered. Discounts must include shipping/ freight charges. A current price list and catalog must be provided at the time of bidding. NOTE: DISCOUNTS MAY BE USED IN DETERMINING AWARDS.			
Manufacturer	Minimum Order	Lead Time	Discount Amount	Discount Detail	FOB - Freight FACTORY - Cost will be extra DESTINATION - Cost is included in discount
Example: ABC Company Inc	\$1,000	1-2 Weeks	25%	2024 List Price Sheet	Destination

 Authorized Agents Signature

 Date

 Bid Number

 Name of Firm



INVITATION FOR BIDS

Bid #26-374, Bleachers, Auditorium Seating, and Other Equipment

ATTACHMENT C – Special Provisions

THESE INSTRUCTIONS SUPERCEDE AND TAKE PRECEDENCE OVER ANY OPPOSING LANGUAGE IN THE STANDARD TERMS AND CONDITIONS

A. SOLICITATION OBJECTIVES

KCDA is seeking manufacturers, providers or dealers/distributors to provide current and emerging Bleachers, Auditorium Seating, and Other Equipment to its members.

Total approximate value of this contract is between \$7 million and \$8 million annually. However KCDA does not guarantee any minimum or maximum value or number of orders.

It is KCDA's intent to establish an annual multi-state contract with the potential of up to three (3) one-year extensions if mutually agreed between KCDA and the awarded vendor(s). Bidders must be a manufacturer or a manufacturer's sales representative authorized to provide KCDA members with Bleachers, Auditorium Seating, and Other Equipment in Washington, with the preferred ability to service surrounding member states (ex: Oregon, Idaho, Montana, Alaska).

Contracts established by KCDA are available for use by all public schools, colleges, universities, cities, counties and other government agencies throughout the nation. Participation in KCDA is not required of any governmental agency; however, participation does provide the legally required competition for contracts for commonly purchased products and services, thereby saving the entity the time and expense of a required competitive process. As allowed by specific state statutes, members can issue purchase orders for any amount without the necessity to prepare their own IFB or gather necessary quotations.

Bidders must be an authorized manufacturer, sales representative or service dealer having a local sales, service and install presence in Washington State. The Bidder must also include a list identifying the states within which they are authorized to sell, service and install. If a portion of a state is serviced, bidder must specifically list the portion which is serviced. Bidder can list by county, region or territory. Bidder must provide the list as a separate document when submitting a response. The bidder may propose different pricing and rates for different installation areas as necessary to accommodate applicable wage rates and costs. Bidders must have a local sales presence that either reside or can be contacted within the additional states named to enable KCDA members to have onsite consultation, needs assessment, installation, integration and training.

It is the intent of KCDA to award a contract, whereas KCDA member agencies can get products for Bleachers, Auditorium Seating, and Other Equipment that will meet the needs they will want during the year.

The types of services and products may include, but are not limited to Bleachers, Auditorium Seating, and Other Equipment that match the specification sheet requirements mentioned in the bid documents. By conducting this solicitation, KCDA intends to provide savings and to offer its members a choice of Bleachers, Auditorium Seating, and Other Equipment at discounted pricing.

KCDA's purpose is to:

- Cooperatively serve our members and associate members through a continuous effort to explore and solve present and future purchasing needs.
- Provide government agencies opportunities for greater efficiency and economy in acquiring goods and services.
- Equalize purchasing power for smaller agencies that are unable to command the best contracts for themselves.
- Maintain credibility and confidence in business procedures by maintaining open competition for purchases and complying with purchasing laws and ethical business practices.
- Provide competitive price solicitations which meet the procurement laws of our members.
- Secure multi-state volume purchasing contracts which are measurable, cost effective and continuously exceed our members' expectations.
- Provide quick and efficient delivery of goods and services by contracting with "high performance and quality" vendors who understand our members' needs.

B. TIMELINE

April 24, 2026 & May 1 st , 2026	Advertised as Bid #26-374 in DJC Seattle, Oregon
June 4, 2026	Bids due no later than 2:00 P.M. PST
July 13, 2026	Award Recommendation
July 21, 2026	Board Approval
August 1, 2026	Contract Start Date

C. SUBMISSION OF BIDS

Bidders are requested to submit pricing for Washington state per the drawings and specifications provided in this solicitation. KCDA requests pricing for its members in Oregon, Idaho, Montana and Alaska as well. Bidder is requested to submit either 1) separate price pages for each state being bid or 2) provide a pricing matrix that shows a price factor to be applied to the Washington state pricing in order to calculate the pricing for other states. Pricing must be provided in hard copy and must be available in excel on flash drive or CD.

Online submission of bid through Public Purchase is NOT accepted.

- Submit sealed bids in 3-ring binder with an inside pocket and a set of dividers. Submit one (1) bound and signed copy of the bid plus one (1) electronic copy on CD or flash drive.
- KCDA reserves the right to reject any or all bids and to accept any proposal deemed most advantageous to KCDA members and to waive any informality in the bid process.
- Bids shall be submitted as stated in this solicitation. Deviations to any terms, conditions and/or specifications shall be conspicuously noted in writing by the bidder and shall be included with the bid. No cross outs or delineations shall be made to the existing document. Exceptions and deviations will be considered in award evaluation. KCDA reserves the right to reject any deviations or exceptions stipulated in a bidder response, and may subsequently disqualify such bid if such terms are unacceptable to KCDA. Language to the effect that the bidder does not consider this solicitation to be part of a contractual obligation may result in the bid being disqualified.
- Withdrawals of bids will not be allowed for a period of 60 days following the opening. Withdrawal of bids prior to the opening date will be permitted.
- Addendums, if required, will be issued by KCDA through Public Purchase. Addendums will also be posted on the KCDA website (www.kcda.org) under Contracts & Bids – Vendor Bids. Addendums will not be mailed or e-mailed. It is bidder's responsibility to check for issuance of any Addendums prior to submitting a bid. **All Addendums must be signed and returned with the bid document, or the bid may be considered non-responsive.**
- All documents with signatures shall have original ink signatures. Electronic copies shall be scanned with original signatures.

D. BID FORMAT

1. Preparation of the Bid Response

- a. The IFB is published in one PDF document on the KCDA Website, it is also published on the Public Purchase Website with all required documents and forms posted separately.
 - **Attachment A1 Cover Page** indicates due date and where to send bid documents to
 - **Attachment A2 Direct Ship Terms & Conditions**
 - **Attachment A3** Debarment Statement (**signature required**)
 - **Attachment B** Terms by Manufacturer (**signature required**)
 - **Attachment C** Special Provisions (**signature required**)
 - **Attachment D** Manufacturer Price List (**completion required**)
 - **Attachment E1** Miscellaneous Fees (**signature required**)
 - **Attachment E2** Services Price Schedule (**complete, as necessary**)
 - **Attachment F** Deviations (**signature required**)
 - **Attachment G** EDGAR Certification Form (**signature required**)
 - **Attachment H** Company Profile (**signature required**)
 - **Attachment I** Certification of Compliance (**signature required**)
 - **Spec 1** Indoor Telescoping Bleachers specification details
 - **Spec 2** Outdoor Bleachers specification details
 - **Spec 3** Auditorium Seating Specification details
 - **Spec 4** Outdoor Stadium with Press Box and Storage Specification details
 - **Spec 5** Other Equipment – Wall Padding, Movable gym partitions, Curtain Partitions
- b. Bid forms requiring signatures shall be submitted with original ink signatures, by the person authorized to sign the bid. Failure to properly sign the bid documents or to make other notations as indicated will result in the response being deemed non-responsive.
- c. Corrections and/or modifications received after the opening time will not be accepted, except as authorized by applicable rule, regulation or statute and KCDA.
- d. In case of an error in extension of prices in the bid, unit prices shall govern.
- e. Periods of time, stated as a number of days, shall be in calendar days, not business days.
- f. It is the responsibility of all Bidders to examine the entire IFB package, to seek clarification of any item or requirement that may not be clear, and to check all responses for accuracy before submitting a bid. Negligence in preparing a bid confers no right of withdrawal after due time and date.
- g. The Bidders' ability to follow the bid preparation instructions set forth in this solicitation will also be considered to be an indicator of the Bidders' ability to follow instructions should they receive an award as a result of this solicitation. Any contract between the KCDA member and a Bidder requires the delivery of information and data. The quality of organization and writing reflected in the bid will be considered to be an indication of the quality of organization and writing which would be prevalent if a contract was awarded. As a result, the bid will be evaluated as a sample of data submission.

2. Format of Bid Response

Bidders shall provide bids in a three ring binder using standard size paper, clearly identified with the company name and the name of the IFB being responded to on the outside front cover and vertical spine. Clearly identified tabs must be used to separate the bid into sections, as identified below. Responses should be direct, concise, complete and unambiguous. Bidders failing to organize bids in the manner requested risk being considered non-responsive if bids are not easily read and understood. Awards will be made more efficiently and timely by following the required format.

Tab 1 – Attachment H - Company Profile/Information

- Company Profile form

- Responses should include a brief introduction informing KCDA of the qualifications and experience of the Bidder, along with a brief company history.
- Reference requirements: (3-5). Projects should be of similar size and complexity, preference given for government contracts.

Tab 2 - Response Forms

- Attachment A3 - Debarment Statement
- Attachment B - Terms by Manufacturer (option: bidder may include this information in their own format as part of the pricing pages)
- Attachment C - Special Provisions
- Attachment F - Deviations
- Attachment I - Certification of Compliance with Wage Payment Statutes
- Attachment G - EDGAR Certification Form

Tab 3 - Pricing Pages

- Attachment D - Manufacturer price list supplied in IFB. Contract / Vendor Bidder can submit additional price sheets to explain what is being offered for this contract category.
- Attachment E1 - Miscellaneous Fees
- Attachment E2 - Service Price Schedule
- A listing of products or services which are not listed on the price list which Bidder can provide and may be considered as a value add for KCDA member agencies.

Tab 4 - Product Line Brochures and Literature

Tab 5 - Marketing Plan

- List tradeshow and conferences. Show examples of flyers or describe how bidder will market the KCDA contract.

Tab 6 - Authorized Dealers/Vendor Partners

- Provide letters from each manufacturer stating authorization to deal.
- List all dealers/vendor partners authorized to utilize this contract through the vendor.

Tab 7 - Addendums

E. VENDOR RESPONSIBILITIES

- Designate and assign a dedicated senior-level contract manager (one authorized to make decisions) to the KCDA contract. This employee will have a complete copy and must have working knowledge of the contract.
- Train and educate sales staff on what the KCDA contract is including pricing, who can order from the contract, terms/conditions of the contract and the respective ordering procedures for each state. It is expected that the awarded vendor will lead with the KCDA contract.
- Develop a marketing plan to support the KCDA contract in collaboration with respective KCDA member agencies. Plan should include, but not be limited to, a website presence, electronic mailings, sales flyers, brochures, mailings, catalogs, etc.
- Create a KCDA-specific sell sheet with a space to add a KCDA logo and contact information for use by KCDA and the awarded vendors local sales representatives to market within each state.
- Have ongoing communication with the Contract and Procurement Specialist at KCDA and the KCDA member agencies.
- Attend two (2) "touch base" meetings at KCDA per year. One of those meetings may be participating in the KCDA Vendor Fair.
- Participate in national and local conference trade shows to promote the KCDA contract.
- Increase sales over the term of the KCDA contract.

F. EQUIPMENT & RELATED PRODUCTS

1. New Bleachers, Auditorium Seating, and Other Equipment:

All Bleachers, Auditorium Seating, and Other Equipment provided under this contract must be new. New Bleachers, Auditorium Seating, and Other Equipment which have not been used previously and are being actively marketed by the manufacturers' authorized dealers.

All branded Bleachers, Auditorium Seating, and Other Equipment components, spare parts, application software, and ancillary equipment supplied under this contract must conform to manufacturer specifications and shall be of new manufacture and in current standard production. The awarded vendor is responsible for ensuring that these items are operable and installed in accordance with manufacturer's specifications.

See the Attachment D Manufacturer Price List for specifications for the product details.

2. Bleachers, Auditorium Seating, and Other Equipment Installation/Removal

- a. The installation and/or removal of contract Bleachers, Auditorium Seating, and Other Equipment shall be performed in a professional manner. The members' premises and equipment shall be left in a clean condition. The awarded vendor may be required to repair all damage and/or provide full compensation for damage to the member agencies' premises and equipment that occurred during installation/removal.
- b. Personnel in charge of the installation must be available to coordinate installation with member agency's internal staff. Qualified service support and technical personnel will be required to provide all necessary maintenance and repair. Installation dates and installation schedule must be approved by member agency.
- c. Installation crews may be working around students, teachers and general staff. Installation may require off hour and weekend work in order to accommodate and complete the project in the timeline required by the member agency. The member agency will try to accommodate access for installation during school/business hours; however, any plan that displaces staff, students or personnel will most likely create disruption to the ordinary daily schedule. After hours and weekend installations are preferred and will be so identified in the proposal to the member agency.
- d. Project Manager for the awarded vendor shall verify proper installation at multiple and various times throughout the duration of the installation.
- e. Upon successful completion of installation, test system functionality for all possible scenarios and document all outcomes.
- f. Installment requirements (electrical certifications, plumbing certifications, licenses, permits etc.).

3. Bleachers, Auditorium Seating, and Other Equipment Problems

Member agency will evaluate the performance of newly installed Bleachers, Auditorium Seating, and Other Equipment for a 15-day period after installation. If the performance is unsatisfactory, the member agency will immediately contact the awarded vendor to pursue corrective action and resolution of the problem. Resolution of performance problems may result in:

- Repair or other action to correct the problem including training or modifications made to member's satisfaction
- The replacement of the Bleachers, Auditorium Seating, and Other Equipment with another Bleachers, Auditorium Seating, and Other Equipment of the same brand and model, at no additional cost (including delivery and installation) to the member agency, or –
- Return of the Bleachers, Auditorium Seating, and Other Equipment with cancellation of the order at no charge to the member agency.

4. Bleachers, Auditorium Seating, and Other Equipment Inspection/Testing/Acceptance

- a. Inspections, tests, measurements, or other acts or functions performed by the member agency shall in no manner be construed as relieving the awarded vendor from full compliance with contract requirements. At a minimum, an installed piece must demonstrate the capability of providing the functions and services specified in the manufacturer's published literature.
5. Bleachers, Auditorium Seating, and Other Equipment Maintenance, Repair and Service
 - a. Maintenance, repair and service related to the operation of Bleachers, Auditorium Seating, and Other Equipment must be provided to member agency.
 - b. Excessive Service and Downtime: Bleachers, Auditorium Seating, and Other Equipment including all components, spare parts, application software, and ancillary equipment supplied through this contract shall be capable of continuous operation. Therefore, awarded vendor shall guarantee that all Bleachers, Auditorium Seating, and Other Equipment will be operational at least 98% of normal business hours. Bleachers, Auditorium Seating, and Other Equipment that develop a trend of requiring an excessive number of service calls shall be reported by the member agency to the awarded vendor or by the awarded vendor to the member agency as the situation warrants and a corrective action and resolution will be made in a manner that is best for the member agency.
 - c. In the event that the performance of maintenance services under the contract results in a need to replace defective parts, such items may only be replaced by new parts. In no instance shall the awarded vendor be permitted to replace defective items with refurbished, remanufactured, or surplus items without prior written authorization of the member agency.
 - d. Awarded vendor must guarantee the availability of repair parts for a minimum of five (5) years subsequent to member agencies acceptance of the contracted Bleachers (Indoor or Outdoor), Auditorium Seating, and Other Equipment.
 6. Bleachers, Auditorium Seating, and Other Equipment Relocation/Transfer
 - a. Member agencies shall be afforded the option to relocate/transfer contract Bleachers, Auditorium Seating, and Other Equipment from one member location to another member location as deemed necessary with no change to agreement or maintenance plans. If self-moves are an option, the awarded vendor must be notified prior to relocating or transferring. The member agency will be responsible for repairs required for damage that occurred during self-moves.
 - b. Alternately member agencies may elect to have the awarded vendor relocate/transfer the Bleachers, Auditorium Seating, and Other Equipment. The awarded vendor is responsible for repairs required following such relocation/transfer. Relocation/transfer of Bleachers, Auditorium Seating, and Other Equipment must be coordinated with member agency contact personnel responsible for the contract.
 7. Bleachers, Auditorium Seating, and Other Equipment New Products and/or Services

Bleachers, Auditorium Seating, and Other Equipment must meet the scope of work to be added to the contract. Pricing shall be equivalent to the percentage discount for other products. Awarded vendor may replace or add product lines to an existing contract if the line is replacing or supplementing products on contract, is equal or superior to the original products offered, is discounted in a similar or to a greater degree, if it is within the same awarded manufacturer and if the products meet the requirements of the solicitation. No products may be added to avoid competitive procurement requirements. KCDA may require additions to be submitted with documentation from KCDA members demonstrating an interest in, or a potential requirement for, the new product or service. KCDA may reject any additions without cause.
 8. Bleachers, Auditorium Seating, and Other Equipment Discontinued Products

If a product or model is discontinued by the manufacturer, awarded vendor may substitute a new product or model if the replacement product meets or exceeds the specifications and performance of the discontinued model, it is within the awarded manufacturer and if the

discount is the same or greater than the discontinued model.

NOTE: Listing the above specifications shall in no way relieve the awarded vendor from the responsibility to follow proper code and regulations.

G. TRAINING & SUPPORT

If applicable, please state specifically the amount of training which will be provided at no charge. Then list the charge per hour for additional training, if applicable (see Bid Sheet).

- a. If specified by the member agency, staff in-service shall be offered following the installation. Training needs must be quantified and specified by the member agency. Awarded vendors shall provide appropriate pricing (if applicable) based upon each member agency's training need. It is understood that some training may be provided free of charge and some may incur charges. Please outline your training philosophy and related pricing structure.
- b. If desired, follow up training may also be scheduled to further support usage and to identify any individual training needs. Please include follow up training pricing as well.

H. PUBLIC WORKS LANGUAGE

Vendor agrees that, in performance of the services required under this agreement, vendor shall abide by all federal, state, local and Washington law and regulations that may apply to construction and public works. It is the responsibility of the vendor to determine applicability and requirements of any such laws and to abide by them.

1. Public Works

State of Washington statute requires workers be paid prevailing wages when employed on public works projects and on public building service maintenance contracts. (RCW 39.04.010, RCW 39.12.010 and 020) It is the contractor's responsibility to be acquainted with and comply with state regulations regarding payment of prevailing wages on public works projects. Prevailing wages are established by the Washington State Department of Labor and Industries and can be obtained on the web at <https://secure.lni.wa.gov/wagelookup/> or by contacting Labor and Industries at 360-902-5335. A printed copy may also be requested from KCDA. KCDA serves all counties in Washington State. The county in which the project is located will be identified once a member initiates a request for the service, and the effective wage rate to be applied to a specific project is to be based on the date of this bid during the original contract term, and if contract extensions are granted, the prevailing wage rate in effect at the time of the latest extension.

Application: The Public Works Act regulates wages paid to workers, laborers and mechanics performing public work. It does not apply to work that is clerical, executive administrative or professional in nature. It does not apply to work of a secretary, engineer or administrator, unless they are performing construction work, alteration work, repair work, etc. Prevailing wage application depends on the work that is performed, regardless of the worker's job title. (RCW 39.12.020 and WAC 296-128-510 through 530)

Definition: Public Works is all work, construction, alteration, repair or improvement that is executed at the cost of the state or any other local public agency. This includes, but is not limited to, demolition, remodeling, renovation, road construction, building construction, ferry construction and utilities construction. (RCW 39.04.010)

Public Building Service Maintenance Contracts: Prevailing wages are also required on all public building service maintenance (janitorial) contracts. (RCW 39.12.020)

Identification of Licensed Subcontractors: RCW 39.30.060 Bids on public works—Identification, substitution of licensed subcontractors.

(1) Every invitation to bid on a prime contract that is expected to cost \$1,000,000 or more for the construction, alteration, or repair of any public building or public work of the state or a state agency or

municipality as defined under RCW 39.04.010 or an institution of higher education as defined under RCW 28B.10.016 shall require each prime contract bidder to submit:

(a) At the published bid submittal time, the names of the licensed subcontractors and proof of license with whom the bidder, if awarded the contract, will subcontract for performance of the work of: HVAC (heating, ventilation, and air conditioning); plumbing as described in chapter 18.106 RCW; and electrical as described in chapter 19.28 RCW, or to name itself for the work, if it is licensed to perform the work for which it has named itself. Errors identified by the contracting agency in the proof of license information must be corrected by the bidder within 48 hours of submission; and

(b) Within 48 hours after the published bid submittal time, the names of the subcontractors with whom the bidder, if awarded the contract, will subcontract for performance of the work of structural steel installation and rebar installation.

(2) The prime contract bidder shall not list more than one subcontractor for each category of work identified, unless subcontractors vary with bid alternates, in which case the prime contract bidder must indicate which subcontractor will be used for which alternate. Failure of the prime contract bidder to submit as part of the bid the names of such subcontractors or to name itself to perform such work or the naming of two or more subcontractors to perform the same work shall render the prime contract bidder's bid nonresponsive and, therefore, void.

(3) Substitution of a listed subcontractor in furtherance of bid shopping or bid peddling before or after the award of the prime contract is prohibited and the originally listed subcontractor is entitled to recover monetary damages from the prime contract bidder who executed a contract with the public entity and the substituted subcontractor but not from the public entity inviting the bid. It is the original subcontractor's burden to prove by a preponderance of the evidence that bid shopping or bid peddling occurred.

Substitution of a listed subcontractor may be made by the prime contractor for the following reasons:

(a) Refusal of the listed subcontractor to sign a contract with the prime contractor;

(b) Bankruptcy or insolvency of the listed subcontractor;

(c) Inability of the listed subcontractor to perform the requirements of the proposed contract or the project;

(d) Inability of the listed subcontractor to obtain the necessary bonding, insurance, or other statutory requirements to perform the work detailed in the contract;

(e) Refusal or inability to provide a letter of bondability from a surety company; or

(f) The listed subcontractor is barred from participating in the project as a result of a court order or summary judgment.

(4) The requirement of this section to name the prime contract bidder's proposed subcontractors applies only to proposed HVAC, plumbing, electrical, structural steel installation, and rebar installation subcontractors who will contract directly with the prime contract bidder submitting the bid to the public entity.

(5) This section does not apply to design-build requests for proposals under RCW 39.10.330, to general contractor/construction manager requests for proposals under RCW 39.10.350, or to job order contract requests for proposals under RCW 39.10.420.

Apprentice Utilization Requirements (AURs): RCW 39.04.320 Apprenticeship training programs—Public works contracts—Adjustment of specific projects—Report and collection of agency data—Apprenticeship utilization advisory committee created.

(1)(a)(i) Except as provided in (b) through (d) of this subsection, from January 1, 2005, and thereafter, for all public works estimated to cost \$1,000,000 or more, all specifications must require that no less than 15 percent of the labor hours be performed by apprentices.

(ii) As of July 1, 2024, for all public works contracts awarded by a municipality estimated to cost \$2,000,000 or more, all specifications must require that no less than 15 percent of the labor hours be performed by apprentices. For contracts advertised for bid on or after July 1, 2026, for all public works contracts awarded by a municipality estimated to cost \$1,500,000 or more, all specifications must require that no less than 15 percent of the labor hours be performed by apprentices. For contracts advertised for bid on or after July 1,

2028, for all public works contracts awarded by a municipality estimated to cost \$1,000,000 or more, all specifications must require that no less than 15 percent of the labor hours be performed by apprentices.

(b) For contracts advertised for bid on or after July 1, 2020, for all public works by the department of transportation estimated to cost \$2,000,000 or more, all specifications must require that no less than 15 percent of the labor hours be performed by apprentices.

(c) For contracts advertised for bid on or after January 1, 2010, for all public works by a school district estimated to cost \$1,000,000 or more, all specifications must require that no less than 15 percent of the labor hours be performed by apprentices.

(d) For contracts advertised for bid on or after January 1, 2012, for all public works by a four-year institution of higher education estimated to cost \$1,000,000 or more, all specifications must require that no less than 15 percent of the labor hours be performed by apprentices.

(2) Awarding entities may adjust the requirements of this section for a specific project for the following reasons:

(a) The demonstrated lack of availability of apprentices in specific geographic areas;

(b) A disproportionately high ratio of material costs to labor hours, which does not make feasible the required minimum levels of apprentice participation;

(c) Participating contractors have demonstrated a good faith effort to comply with the requirements of this section; or

(d) Other criteria the awarding entity deems appropriate, which are subject to review by the office of the governor or the municipality's legislative authority if the awarding entity is a municipality.

(3) The secretary of the department of transportation shall adjust the requirements of this section for a specific project for the following reasons:

(a) The demonstrated lack of availability of apprentices in specific geographic areas; or

(b) A disproportionately high ratio of material costs to labor hours, which does not make feasible the required minimum levels of apprentice participation.

(4)(a) This section applies to public works contracts awarded by the state, to public works contracts awarded by school districts, to public works contracts awarded by state four-year institutions of higher education, and to public works contracts awarded by a municipality. However, this section does not apply to contracts awarded by state agencies headed by a separately elected public official or housing authorities as defined in RCW 35.82.020.

(b) Within existing resources, awarding agencies and municipalities are responsible for monitoring apprenticeship utilization hours by contractor. There must be a specific line item in the contract specifying that apprenticeship utilization goals should be met, monetary incentives for meeting the goals, monetary penalties for not meeting the goals, and an expected cost value to be included in the bid associated with meeting the goals. The awarding agency and municipality must report the apprenticeship utilization by contractor and subcontractor to the supervisor of apprenticeship at the department of labor and industries by final project acceptance. The electronic reporting system that is being developed by the department of labor and industries may be used for either or both monitoring and reporting apprenticeship utilization hours.

(c) In lieu of the monetary penalty and incentive requirements specified in (b) of this subsection, the Washington state department of transportation may use its three strike system for ensuring compliance including the allowance for a good faith effort.

(5)(a) The department of labor and industries must provide information and technical assistance to affected agencies and municipalities, and collect the following data from affected agencies and municipalities for each project covered by this section:

(i) The name of each apprentice and apprentice registration number;

(ii) The name of each project;

(iii) The dollar value of each project;

(iv) The date of the contractor's notice to proceed;

(v) The number of apprentices and labor hours worked by them, categorized by trade or craft;

(vi) The number of journey level workers and labor hours worked by them, categorized by trade or craft; and

(vii) The number, type, and rationale for the exceptions granted under subsection (2) of this section.

(b) The department of labor and industries and the municipal research and services center shall provide training, information, and ongoing technical assistance to municipalities in order to comply with apprenticeship utilization requirements. Training must include, but not be limited to, department of labor and industries reporting requirements, contract administration including sample contract language, and best practices on how a municipality's governing authority must adopt apprenticeship guidelines, including procedures, rules, and instructions to ensure compliance relating to a contractor that seeks a good faith waiver of apprenticeship utilization requirements.

(c) The department of labor and industries shall provide information and technical assistance with apprenticeship utilization reporting. The department of enterprise services shall make available sample contract language and provide contract administration advice pertaining to apprenticeship requirements.

(6) The secretary of transportation shall establish an apprenticeship utilization advisory committee, which must include statewide geographic representation and consist of equal numbers of representatives of contractors and labor. The committee must include at least one member representing contractor businesses with less than 35 employees. The advisory committee shall meet regularly with the secretary of transportation to discuss implementation of this section by the department of transportation, including development of the process to be used to adjust the requirements of this section for a specific project.

(7) At the request of the senate labor, commerce, research and development committee, the house of representatives commerce and labor committee, or their successor committees, and the governor, the department of enterprise services and the department of labor and industries shall compile and summarize the agency and municipality data and provide a joint report to both committees. The report must include recommendations on modifications or improvements to the apprentice utilization program and information on skill shortages in each trade or craft.

(8) All contracts subject to this section must include specifications that a contractor or subcontractor may not be required to exceed the apprenticeship utilization requirements of this section.

(9) This section establishes the minimum apprenticeship utilization requirements on public works contracts awarded by a municipality. Any standards or requirements relating to apprenticeship utilization established by any applicable local law or ordinance that are more favorable to apprentices than the minimum requirements under this section are not affected by this section and those more favorable laws apply and may be enforced as provided by law.

Reciprocity: In accordance with RCW 39.04.380 any bidding process for public works in which a bid is received from a nonresident contractor from a state that provides a percentage bidding preference, a comparable percentage disadvantage must be applied to the bid of that nonresident contractor. This does not apply to public works procured pursuant to RCW 39.04.155, 39.04.280 or other procurement exempt from competitive bidding.

2. Prevailing Wage

Definition: Prevailing Wage is the hourly wage, usual benefits and overtime, paid in the largest city in each county, to the majority of workers, laborers and mechanics. The rate is established by the Department of Labor and Industries for each trade and occupation employed in the performance of public work. If Federal funds are used, bidders must comply with provisions of Davis-Bacon Act.

Basic procedures: A Statement of Intent to Pay Prevailing Wages and Affidavit of Wages Paid must be filed and approved for the contractor and all subcontractors. No payments can be made until all contractors/subs have submitted an approved intent form. KCDA cannot release retainage until all contractors have an approved Affidavit of Wages Paid form certified by the Industrial Statistician. (RCW 39.12.030, 040, 042) Once the work is successfully completed, KCDA will release 95% of the project cost and withhold 5% retainage for 45 days as dictated by law. The final 5% will be paid when the following is

completed: Receipt of approved Affidavit of Wages Paid Forms, releases from Washington State Department of Labor & Industries, Employment Security Department and the Department of Revenue, and acceptance of project completion to the satisfaction of the KCDA ordering member. **The cost of filing required Intents and Affidavits is the responsibility of the contractor, and may not be added as a line item charged to the member agency. All Intents and Affidavits must name the agency for whom work is being performed as the contract award agency, not KCDA.**

Federally Funded Projects: In addition to the Federal Requirements of Section III, Housing and Urban Development (HUD) Terms and Conditions, **Davis-Bacon** prevailing wage requirements apply to public works construction contracts of \$2,000 or more when a project includes any federal funding of any amount. When there is a difference between applicable state and federal prevailing wages for a particular classification of labor, contractors and subcontractors are required to pay the higher of the two prevailing wages. Applicable federal prevailing wage determinations can be found at <https://sam.gov/content/wage-determinations>. Contractors/subcontractors must be knowledgeable and adhere to all federal prevailing wage requirements, including but not limited to, paying workers weekly and providing certified weekly payrolls for the contractor and subcontractors of any tier, to the member agency for their review and verification, as required in the Davis-Bacon Act and applicable U.S. Department of Labor regulations. Falsification of any prevailing wage payroll records may subject the contractor or subcontractor to civil or criminal prosecution under section 1001 of Title 18 and section 3729 of Title 31 of the United States Code. Contractor shall inform all subcontractors of the Davis-Bacon requirements and the prime contractor shall be responsible for the compliance by any subcontractor or lower tier subcontractor with all the contract clauses. Contractor must coordinate all requirements related to federal funded projects with the KCDA member agency.

3. Responsible Bidder

Before award, the bidder must meet the following state responsibility criteria and, if applicable, supplemental responsibility criteria to be considered a responsible bidder. The bidder is required to submit documentation demonstrating compliance with the criteria.

Low Responsible Bidder

State Responsibility Criteria. The bidder must meet the following state responsibility criteria:

1. At the time of bid submittal, have a current certification of registration in compliance with chapter 18.27 RCW.
2. Have a current Washington State Unified Business Identifier (UBI) number.
3. Not be disqualified from bidding on any public works contract under RCW 39.06.010 or 39.12.065(3).
4. If applicable:
 - a. Have Industrial Insurance (workers' compensation) coverage for the bidder's employees working in Washington State, as required in Title 51 RCW;
 - b. Have a Washington State Employment Security Department number, as required in Title 50 RCW; and
 - c. Have a Washington State Department of Revenue state excise tax registration number, as required in Title 82 RCW.
5. New bidder requirement. Certify that within the three-year period immediately preceding the bid solicitation date:
 - a. The bidder is not a "willful" violator, as defined in RCW 49.48.082, of any provision of chapter 49.46, 49.48 or 49.52 RCW.
 - b. As determined by a final and binding citation and notice of assessment issued by the Department of Labor and Industries or through a civil judgement entered by a court of limited or general jurisdiction.
 - c. As of July 1, 2019, WA Labor and Industries has required all businesses to have public works training before bidding and/or performing work on public works projects. This training requirement has been added to the responsible bidder criteria in RCW 39.04.350 and RCW 39.06.020. Awarding agencies

are required to verify all contractors submitting bids meet this requirement before awarding the contract.

6. At the time of bid submittal, provide signed sworn statement in accordance with RCW 9A.72.085 verifying under penalty of perjury that the bidder is in compliance with the new responsible bidder criteria requirement.
7. Supplemental Bidder Responsibility Criteria. If supplemental criteria apply to this project, the criteria are included as "Exhibit A." The bidder may make a written request to modify any or all of the supplemental criteria. Modification of supplemental criteria shall be at KCDA's discretion. Any modifications to the supplemental criteria shall be made by addenda prior to bid opening.

Subcontractor Responsibility

The contractor shall include the language of this section in each of its first tier subcontracts, and shall require each of its subcontractors to include the same language of this section in each of their subcontracts, adjusting only as necessary the terms used for the contracting parties. The requirements of this section apply to all subcontractors regardless of tier. At the time of subcontract execution, the contractor shall verify that each of its first tier subcontractors meets the following bidder responsibility criteria:

1. At the time of bid submittal, have a current certification of registration in compliance with chapter 18.27 RCW.
2. Have a current Washington State Unified Business Identifier (UBI) number.
3. Not be disqualified from bidding on any public works contract under RCW 39.06.010 or 39.12.065(3).
4. If applicable:
 - a. Have Industrial Insurance (workers' compensation) coverage for the bidder's employees working in Washington State, as required in Title 51 RCW;
 - b. Have a Washington State Employment Security Department number, as required in Title 50 RCW; and
 - c. Have a Washington State Department of Revenue state excise tax registration number, as required in Title 82 RCW
5. Have an electrical contractor license, if required by Chapter 19.28 RCW;
6. Have an elevator contractor license, if required by Chapter 70.87 RCW;

4. Payment & Performance Bond

The prime contractor shall provide a Performance and Payment Bond at 100% of the contract price to the KCDA member with a copy to KCDA before work begins. The only exception is for contracts of one hundred fifty thousand (\$150,000) dollars or less. In this instance, at the option of the contractor, the member may in lieu of the bond retain ten percent of the contract amount for a period of thirty days after date of final acceptance, or until receipt of all necessary releases from the Department of Revenue, Employment Security Department, and the Department of Labor and Industries and settlement of any liens filed under Chapter 60.28 RCW, whichever is later. The bond shall be issued by a surety company authorized to do business in the State of Washington and shall be on standard forms used for public projects (RCW 39.08.010) and as directed by the KCDA member.

Performance and Payment bonds for KCDA members outside Washington must be provided by companies licensed to provide bonds for public entities in the member's state.

5. Licenses

The prime contractor shall possess and maintain in current status all federal, state, and local licenses, bonds, and permits required for the performance and delivery of any and all products and services offered in its response to the bid solicitation. Before submitting a bid, bidders must hold a current, valid contractor's license as required in Washington. The contractor's license must be in the name of the legal entity submitting and signing the bid. A bidder may not substitute a contractor's license held by a subcontractor or joint venture. Bidders submitting bids in Washington State without a valid contractor's license in the name of the bidder are in violation of RCW 18.27.020.

It is the responsibility of the prime contractor to ensure any subcontractors performing under this contract hold and maintain appropriate licenses.

KCDA reserves the right to request copies of licenses at any time during the contract. Copies of licenses, upon request, must be submitted to the member prior to performing the work. The contractor agrees to keep and ensure subcontractors keep any required license, permit or bond current and in compliance with Washington rules, regulations and statutes, as well as in states outside Washington in which contractor performs work under this contract. For work performed for any Washington State school district, public agency or municipality, the contractor must comply with the bidder responsibility requirements of RCW 39.04.350 prior to the KCDA member awarding a contract. The contractor must verify the responsibility of all subcontractors used in accordance with RCW 39.06.020.

6. Permits

Obtaining permits is the responsibility of the member. Awarded contractor may provide guidance and/or assistance in obtaining necessary permits. If contractor does obtain permits on behalf of member, all fees are viewed as a “pass through” with no upcharge to the member.

7. Certificate of Insurance

A certificate of insurance demonstrating current coverage of the types and amounts of insurance required by KCDA and the KCDA member must be provided to the KCDA member prior to performance of any work. In addition, the Commercial General Liability policies must be endorsed to name KCDA and the KCDA member as additional insureds. Such policies must be further endorsed to provide that the insurance is primary as respects KCDA and the KCDA member, and that any other insurance maintained by KCDA and the KCDA member shall be excess and not contributing insurance with the contractor’s insurance. These endorsements must be provided along with the certificate of insurance. The KCDA member must approve the certificate of insurance and endorsements.

8. Acceptable Pricing Method

KCDA is unable to accept Alternative Costing Method quotations except in certain limited instances, (i.e. sole source) in which KCDA and vendor may mutually determine the Alternative Costing Method is acceptable. This will be the exception rather than the rule. RS Means or line item bid pricing is acceptable.

9. Progress Payments

The contractor shall be paid, upon submission of a proper Payment Request, the prices stipulated herein for work performed (less deductions, if any), in accordance with all payment and retainage instructions herein. Submitted Payment Requests must contain the following minimum information:

1. Contract Number
2. Bid item ID, bid quantity, unit, unit price and description as appropriate
3. Sales Tax as applicable

The Payment Request will be reviewed by the member before payment is made. If the member is in disagreement with the Payment Request, KCDA will issue a notice requesting a revised Payment Request.

KCDA, at its discretion, reserves the right to withhold payment on a given project, pending receipt of payment from the customer.

In accordance with RCW 51.12.050, KCDA reserves the right to deduct from the payment any outstanding industrial insurance premiums owed by the contractor or subcontractors.

10. Payment Retainage

In accordance with RCW 60.28 contract retainage [*not to exceed five percent of the moneys earned by the contractor toward completion of a public improvement contract*] shall be withheld and reserved in one of two ways:

1. As a trust fund for the protection and payment of 1) the claims of any person arising under the contract, and 2) the state with respect to taxes imposed pursuant to Titles 50, 51 and 82 RCW which may be due from such contractor. Upon completion of a contract, the member agency shall notify the Department of Revenue, the Employment Security Department, and the Department of Labor and Industries of the completion of contracts over thirty-five thousand dollars. KCDA will issue payment on the retainage amount forty-five days after notice from the KCDA member agency that the contract has been accepted as complete or upon receipt of all necessary releases, whichever is later.
2. Option of providing retainage bond for the full amount of the retainage (5% of the contract amount with a performance bond). This bond is separate from the performance bond under RCW 39.08.10. Providing a retainage bond means no retainage is withheld. If you choose to provide a retainage bond a copy of the bond must be submitted.

11. Force Majeure

Except for payments of sums due, neither party shall be liable to the other, nor be deemed in default under this contract, if and to the extent that such party's performance of this contract is prevented by reason of force majeure. The term "force majeure" means an occurrence that is beyond the control or responsibility of the party affected and occurs without its fault or negligence, including, but not limited to the following: acts of God; acts of the public enemy; war; riots; strikes; industry-wide labor disputes; civil disorders; fire; flood; snow; earthquakes; tornadoes or violent winds; hail storms; lockouts; injunctions-intervention-acts, or failures or refusals to act by government authority; and other similar occurrences beyond the control or responsibility of the party declaring force majeure, which such party is unable to prevent by exercising reasonable diligence. The force majeure shall be deemed to commence when the party declaring it notifies the other party of the existence of the force majeure, and shall be deemed to continue as long as the results or effects of the force majeure prevent the party from resuming performance in accordance with the contract. The party receiving the notice of force majeure may contest the declaration of a force majeure. Force majeure shall not include late deliveries of equipment or materials caused by congestion at a manufacturer's plant or elsewhere, an oversold condition of the market, inefficiencies, internal labor disputes, or similar occurrences. If either party is delayed at any time by force majeure, the delayed party shall notify the other party in writing of such delay within forty-eight (48) hours.

I. PRICING

IFB - The bidder shall submit pricing on the Pricing Pages included or on Attachment B in this IFB. Vendor bid pricing shall include a 2% administrative fee on all line items and charges. The administrative fee must be part of the bid price. If you are bidding a catalog price less a discount, make sure the administrative fee is included in the net price to the member agency. Pricing must include the 2% KCDA service fee so the service fee is invisible to KCDA members.

For all Bleachers (Indoor or Outdoor), Auditorium Seating, and Other Equipment, pricing may be by line item or discount off manufacturer price list (Attachment B). Accessories and materials may be from other manufacturers or sources, but must be identified and priced in the IFB response either by item or via catalog discount. On the pricing sheet, list and group accessories and materials by manufacturer for ease of identification. Respondents will choose only one pricing method to be used per manufacturer. Alternative pricing methods shall be addressed in Attachment B. Proposals received that provide both for a single manufacturer will be found non-responsive.

Fixed prices shall be firm until each anniversary date of contract, unless there is an occurrence of one or more economic price adjustment contingencies outlined in the bid. If price adjustment contingencies occur, or not less than ninety (90) days prior to each contract anniversary date, awarded vendor may submit a fully documented request for price adjustment to KCDA. The documentation must substantiate that any requested price increase was clearly unpredictable at the time of bid submittal and results from an increased cost to awarded vendor that was out of awarded vendor's control.

KCDA will review requests for fixed price adjustments to determine if the new prices or another option is in member agencies' best interests. If accepted, new fixed prices shall apply to the contract upon approval from KCDA. Price changes shall be a factor in contract renewal.

The awarded vendor agrees that the cost for any item bid on this contract may vary by state due to specific requirements or other jurisdictional impacts. If the overall cost is discounted or lowered for any member agency, however, the cost will be similarly lowered or discounted at the same time for all member agencies for the same scope, size and value. (If a KCDA member agency proposes to purchase a large volume of one product at one time and the awarded vendor agrees to provide an additional discount, that same volume discount would be available to any KCDA member agency.)

It is understood and agreed upon between Bidder and KCDA that the Bidder's pricing does not include the cost for any site specific conditions or requirements. Site specific requirements shall be addressed on a case by case basis at the time the order is placed. Any additional costs are to be priced by methods designated under "Options", or by RS Means, as indicated in bidder's response to this solicitation.

Warranty: Describe the warranties that apply to the products offered in the IFB response and when warranty date will commence. Identify any website links that cover warranty information. The manufacturer has the primary responsibility to honor a manufacturer's warranty. Awarded vendor agrees to assist the member agency reach a solution in a dispute with the manufacturer over a warranty's terms. Any extended manufacturer's warranty will be passed on to the member agencies. List any pricing applicable to warranties in Attachment D Manufacturing Price List of the IFB response.

Risk of Loss or Damage: Awarded vendor shall retain title and control of all goods until they are delivered and received. All risk of transportation and all related charges shall be the responsibility of the awarded vendor. The awarded vendor shall file all claims for visible or concealed damage. The member agency will notify the awarded vendor and/or freight company promptly of any damaged goods and shall assist the freight company/awarded vendor in arranging for inspection. No F.O.B. vessel, car or other vehicle terms will be accepted.

Taxes: Member agencies, who have obtained Bleachers (Indoor or Outdoor), Auditorium Seating, and Other Equipment under the terms of this contract, will be responsible for payment of all taxes such as sales tax, property tax, etc. Awarded vendor must separately list all such taxes on member proposal and subsequent invoice.

J. FUNDING OUT CLAUSE

Any acquisition agreement with a KCDA member agency that exceeds one (1) year shall include a standard "funding out" clause. Such an acquisition is a commitment of the entity's current revenue only, provided the agreement contains either or both of the following provisions:

1. Retains to the entity the continuing right to terminate the contract at the expiration of each budget period during the term of the agreement.
2. Conditioned on a best efforts attempt by the entity to obtain appropriate funds for payment of the acquisition.

K. AUTHORIZED DEALERS/VENDOR PARTNERS

The bidder must secure from the manufacturer, if the bidder is not the manufacturer, a written guarantee executed by the manufacturer that the bidder is an authorized dealer of that manufacturer. This can be submitted as a Manufacturers Guarantee/Manufacturers Certificate, or a statement on the manufacturer's letterhead with corporate acknowledgement. Failure to provide will result in award disqualification for that manufacturer.

Bidder may propose a network of authorized dealers/vendor partners through whom the bidder intends to perform the contract. Member agencies may be directed to bidders network of authorized dealers/vendor partners for Bleachers (Indoor or Outdoor), Auditorium Seating, and Other Equipment, however the

awarded vendor shall be responsible for the actual job performance of each and every authorized dealer/vendor partner. This includes, but is not limited to proper ordering process and reporting, or submittal of 2% service fee. Unresolved problems with the authorized dealer/vendor partner may be referred to the awarded vendor for resolution. Bidders are to identify and list each of the authorized dealers/vendor partners they intend to involve in contract performance.

Awarded vendor must be capable of replacing authorized dealers/vendor partners found unsuitable to participate in performance on the KCDA contract, and establish new authorized dealers/vendor partners in a timely manner.

During the contract period, the awarded vendor or purchasing agent may remove an authorized dealer/vendor partner from the list of those designated to this contract at any time without further explanation or process. The awarded vendor may propose authorized dealer/vendor partner additions for consideration at any time throughout the contract provided;

- The request is in writing on awarded vendors letterhead.
- It is filed with the Purchasing Agent a minimum of 30 calendar days before the effective date of the proposed change;
- It clearly identifies the authorized dealers/vendor partners involved in the change;
- It is accompanied by documentation acceptable to the Purchasing Agent sufficient to warrant the change.

L. AWARD

1. Evaluation

It is the intent of KCDA to award a manufacturer’s complete line of products based on the specifications provided when possible and advantageous. KCDA expects to award to the lowest responsive and responsible bidder per unique manufacturer specifications that meet IFB terms, conditions, and criteria specified. An award is at the sole discretion of KCDA. KCDA reserves the right to reject any or all proposals, accept the proposal(s) that are deemed most advantageous for KCDA member agencies, and waive any irregularities in the solicitation process.

Awarded vendors will be required to turn in updated specifications for the manufacturers awarded.

The following criteria will be used in evaluating responses to this IFB. An award is anticipated to be made to a bidder with the highest rating per manufacturer product line. Subsequently, multiple awards may be made.

Evaluation Criteria and Weight

Proper submission of proposal of Bid Documents	5
Vendor compliance and standards / codes	15
Pricing	35
Technical details of products Quality of product, Accessories meet scope, Annual inspection services, Warranty coverage	10
Technical details to design of products Design services offered, products meet compliance code – standards, product safety features	10
Qualification offered by Vendor	15

Provides sales data from past, references, shows past projects, provides authorized user letters from manufacturers	
Service provided to customers Additional services provided to customers, Local presence in the market, and others spare parts	10
TOTAL POSSIBLE POINTS	100

Clarification and/or Discussions

Clarification of a response may be necessary. KCDA will communicate with the bidder(s) for the purpose of eliminating minor errors, clerical errors, and/or irregularities. Clarification is accomplished by explanation or substantiation, either in response to an inquiry from KCDA or an inquiry initiated by a bidder. Clarification does not give a bidder the opportunity to revise, change or modify their response in any way. Discussion takes place after the initial receipt of proposals. KCDA reserves the right to conduct discussions with bidders whose responses are determined to be reasonably inclined toward receiving a contract award. Discussion may occur when oral or written communications between KCDA and the bidder are conducted for the purpose of clarifying information to determine the acceptability of a response. KCDA will not assist the bidder in bringing the bidder’s response to the same level as other responses received by KCDA. Further, KCDA will make no indication of pricing or other information received from other bidders.

Competitive Range: KCDA reserves the right to establish a competitive range of acceptable responses as part of the evaluation process as defined herein. Responses below the competitive range will be determined to be unacceptable and will not receive further consideration.

M. ORDER PROCESS & REPORTING

1. The awarded vendor must verify that a customer is a KCDA member. A current list of member agencies is posted on the KCDA website under “Membership”. If the customer is not posted on the KCDA website, the awarded vendor must verify membership with the KCDA Contract Specialist. If the customer is not a member, but is eligible to become a member, the Contract Specialist will give the customer instructions regarding the membership process.
2. The awarded vendor will submit a signed and dated proposal or quote to the KCDA member in accordance with the pricing awarded under this contract. **All line items and charges must include the KCDA 2% service fee as a part of the price to the member agency. Do not list the 2% fee as a separate line item.** The awarded vendor must specifically state the KCDA contract **#26-374** on the proposal to the KCDA member. The proposal should identify the member contact name, email address and phone number for the person responsible for approving the purchase. This information is critical, and if not provided, may be grounds for delaying the processing of the order as well as eventual payment to the vendor.
3. The KCDA member will draft and submit their purchase order, made out to KCDA, and a copy of the proposal to the Contract Specialist designated on the Awarded Contracts page. Upon KCDA’s verification of membership and pricing, KCDA will create and forward a KCDA purchase order to the designated point of contact at the vendor. The Contract Specialist will request additional information, such as scope of work and item/part numbers, along with pricing for each line item, as needed. Failure to provide adequate evaluation information may result in a delay of approval by Contract Specialist.
4. A copy of the order will be kept on file at KCDA.
5. The awarded vendor must not commence delivery, services or installation using the KCDA contract without receiving a purchase order from KCDA.
6. Orders processed against this contract with customers who are not KCDA members or without emailed approval from KCDA are in violation of contract specifications. Awarded vendors not following proper procedures may be removed from consideration for future awards.

7. Invoicing: The awarded vendor will send invoices to KCDA. KCDA will contact the member to make sure the job is complete or that a progress payment is agreed to. KCDA will then invoice the member. Upon receipt of payment from the member, KCDA will pay the vendor less the 2% service fee, withholding retainage, as necessary.
8. KCDA reserves the right to revise the ordering process above at its discretion, if deemed necessary for contract management or audit purposes. An implementation for change will be coordinated with the awarded vendor.

N. CHRISTIAN DOCTRINE

Any federal, state and local governing authority's/jurisdiction's statutes, codes, rules and regulations referenced and/or govern the products, services and activities relating to and are part of this solicitation, whether or not physically noted or included, shall be complied with and adhered to as required. It is sole responsibility of the Bidder to perform and complete any necessary research and investigation required to make themselves aware of and comply with this item.

Signature _____

Must be same signature that appears on the bid response forms



BID #26-374, BID NAME - Bleachers , Auditorium Seating, Other Equipment

ATTACHMENT D
Manufacturer Price List

Use this layout example to submit bid pricing for all equipment, supplies and other necessary line items and options for Bleachers, Auditorium Seating, and Other Equipment . Items listed should include but not be limited to Telescoping Bleachers, Telescoping Bleachers Parts or Accessorieies, Scoring Tables, Gym Chairs, Curtains or Railings associated with bleachers, ADA ramps with outdoor bleachers, Press Box units for Outdoor Bleachers, Auditorium Seating, Auditorium Seating parts and accessories, Wall Panel Back Stops, Maintenance Services and Inspections, and Other Equipment related to this contract category, and etc.

Category	Product Description	Manufacturer	Mfg. SKU	Vendor SKU	Unit of Measure	List/Retail Price	KCDA Bid price
Telescoping Bleachers							
Bleacher Part and Accessories							
Scoring tables							
Portable Gym Chairs							
Curtains or Rails for Bleachers							
ADA Ramps for Outdoor Bleachers							
Press Box Units for Outdoor Bleachers							
Auditorium Seating							
Auditorium Seating Parts							
Auditorium Seating Numbers							
Auditorium Seating Accessories							



**INVITATION FOR BIDS
BID #26-374, Bleachers, Auditorium Seating, and Other Equipment**

BID DUE DATE: June 4, 2026. On or Before 2:00 PM PST

**Attachment E
SIGNATURE PAGE AND MISCELLANEOUS FEES**

The undersigned offers and agrees, if this bid is accepted, to furnish any or all of the items upon which prices were quoted, at the prices set opposite each item, F.O.B. delivery point specified in the Invitation For Bids, and agrees to make delivery within the delivery dates specified, or as otherwise amended by attachment.

Contract Prices Offered

- 1. Firm for annual contract ()
- 2. Firm for initial order only ()
- 3. Variable by item/group () *(Identify under separate cover)*

MISCELLANEOUS FEES

In some cases, additional charges may be necessary. These costs are for items delivered direct to members. Attach additional pages as may be necessary for each manufacturer. "TBD", "Job by Job" etc. is not acceptable and may disqualify your response. **Bidders should list out any other pricing for services on additional pages as needed within this section.**

Delivery Fee: \$ _____ % or mileage rate
 Installation Fee: \$ _____ per hour
 (comply w/ Prevailing Wage - RCW 39.04.010, 39.12.010 &

020)

Design Fee: \$ _____
 Performance Bond: \$ _____
 Demolition Fee: \$ _____
 Restock Fees: \$ _____
 Lift Gate Fee when required _____ \$ _____
 OTHER _____ \$ _____

NOTE : If services are not documented in pricing pages, fees must be justified by using RS Means.

FUTURE DELIVERIES

On occasion, KCDA members will place orders near the end of the contract period for delivery after the contract period has expired. Will your company honor orders placed during the contract period for future delivery?

_____ No _____ Yes _____ Yes, but only if delivered within 1 / 3 / 6 months (Circle one)

Signed: _____
 Firm Name: _____
 Name and Title: _____
 Telephone No.: _____
 Email: _____

****Note:** All lines of information must be provided with submittal. Electronic acceptance of these terms and conditions signifies compliance with all terms and conditions.

Attachment E2 - Services Price Schedule
KCDA #26-374, Bleachers, Auditorium Seating, and Other Equipment

NOTE: If your company provides any of the services listed below, please complete the price schedule.
If services are not documented in pricing pages, fees must be justified by using RS Means.

Design Services	Description	Regular Price or Rates	Discounted Price or Rates	Per Diem Charges (if any)	Mileage Charges (if any)	*Additional Discount on Large Projects: Y/N

Installation Services	Description	Regular Price or Rates	Discounted Price or Rates	Per Diem Charges (if any)	Mileage Charges (if any)	*Additional Discount on Large Projects: Y/N

Training Services	Description	Regular Price or Rates	Discounted Price or Rates	Per Diem Charges (if any)	Mileage Charges (if any)	*Additional Discount on Large Projects: Y/N
	ex: Initial (must price)					
	Ex: Follow up training (must price)					

Support Services	Description	Regular Price or Rates	Discounted Price or Rates	Per Diem Charges (if any)	Mileage Charges (if any)	*Additional Discount on Large Projects: Y/N

*Please detail additional discounts on large projects.

MISCELLANEOUS FEES

In some cases additional charges may be necessary. These costs are for items delivered direct to member agencies. Attach additional pages as may be necessary for each manufacturer.

Performance Bond: \$ _____
 Shipping: \$ _____
 Lift Gate Fee when required \$ _____ or RS Means
 Rental Scaffolding/Lifts \$ _____ or RS Means
 Raceways \$ _____ or RS Means

FUTURE DELIVERIES

On occasion, KCDA Members will place orders near the end of the contract period for delivery after the contract period has expired.

Will your company honor orders placed during the contract period for future delivery?

No ___ Yes ___ Yes, but only if delivered before _____



**ATTACHMENT F
Deviations**

Bid #26-374, Bid Name – Bleachers, Auditorium Seating, and Other Equipment

INSTRUCTIONS:

1. If “NO” is checked below, complete this form by signing it at the bottom.
2. If “YES” is checked below, either insert answers into this form or create a Microsoft Word table format to provide narrative explanations of exceptions. If adding pages, the bidder’s name and identifying information as to which item the response refers must appear on each page.
3. Scan this form plus any attachments into a single PDF document.
4. Title the file “Attachment F - Deviations”.
5. Exceptions to local, state or federal laws cannot be accepted under this bid.

NO, this bidder does not have deviations (exceptions or alternates) to any terms, conditions and/or specifications listed in the bid documents.

YES, this bidder has the following deviations to the terms, conditions and/or specifications listed in the bid documents.

Section/Item	Specification (describe)	Details of Deviation

Signature _____



Bid #26-374, Bid Name – Bleachers, Auditorium Seating, and Other Equipment

Attachment G - Uniform Guidance “EDGAR” Certification Form 2 CFR Part 200

When a purchasing agency seeks to procure goods and services using funds under a federal grant or contract, specific federal laws, regulations, and requirements may apply in addition to those under state law. This includes, but is not limited to, the procurement standards of the Uniform Administrative Requirements, Cost Principles and Audit Requirements for Federal Awards, 2 CFR 200, referred to as the “Uniform Guidance” or new “EDGAR”. All Respondents submitting proposals must complete this EDGAR Certification form regarding the Respondent’s willingness and ability to comply with certain requirements, which may apply to specific agency purchases using federal grant funds.

For each of the items below, the Respondent will certify its agreement and ability to comply, where applicable, by having the Respondent’s authorized representative check, initial the applicable boxes, and sign the acknowledgment at the end of this form. If a Respondent fails to complete any item of this form, KCDA will consider and may list the response, as the Respondents are unable to comply. A “No” response to any of the items below may influence the ability of a purchasing agency to purchase from the Respondent using federal funds.

Violation of Contract Terms and Conditions

Provisions regarding Respondent default are included in KCDA’s terms and conditions. Any contract award will be subject to such terms and conditions, as well as any additional terms and conditions in any purchase order, ancillary agency contract, or construction contract agreed upon by the Respondent and the purchasing agency, which must be consistent with and protect the purchasing agency at least to the same extent as KCDA’s terms and conditions. The remedies under the contract are in addition to any other remedies that may be available under law or in equity.

Termination for Cause of Convenience

For a participating agency purchase or contract in excess of \$10,000 made using federal funds, you agree that the following term and condition shall apply:

The participating agency may terminate or cancel any purchase order under this contract at any time, with or without cause, by providing seven (7) business days in advance written notice to the Respondent. If this agreement is terminated in accordance with this paragraph, the participating agency shall only be required to pay Respondent for goods and services delivered to the participating agency prior to the termination and not otherwise returned in accordance with the Respondent’s return policy. If the participating agency has paid the Respondent for goods and services provided as the date of termination, Respondent shall immediately refund such payment(s).

If an alternate provision for termination of a participating agency’s purchase for cause and convenience, including how it will be affected and the basis for settlement, is in the participating agency’s purchase order, ancillary agreement or construction contract agreed to by the Respondent, the participating agency’s provision shall control.

Equal Employment Opportunity

Except as otherwise provided under 41 CFR Part 60, all participating agency purchases or contract that meet the definition of “federally assisted construction contract” in 41 CFR Part 60-1.3 shall be deemed to include the equal opportunity clause provided under 41 CFR 60-1.4(b), in accordance with Executive Order 11246, “Equal Employment Opportunity” (30 FR 12319, 12935, 3 CFR Part, 1964-1965 Comp., p. 339), as amended by Executive Order 11375, “Amending Executive Order 11246 Relating to Equal Employment Opportunity,”

and implementing regulations at 41 CFR Part 60, "Office of Federal Contract Compliance Programs, Equal Employment Opportunity, Department of Labor."

Respondent will comply with all Federal statutes relating to nondiscrimination. These include but are not limited to: (a) Title VI of the Civil Rights Act of 1964 (P.L. 88-352) which prohibits discrimination on the basis of race, color or national origin; (b) Title IX of the Education Amendments of 1972, as amended (20 U.S.C. §§1681-1683, and 1685-1686), which prohibits discrimination on the basis of sex; (c) Section 504 of the Rehabilitation Act of 1973, as amended (29 U.S.C. §794), which prohibits discrimination on the basis of handicaps; (d) the Age Discrimination Act of 1975, as amended (42 U.S.C. §§6101-6107), which prohibits discrimination on the basis of age; (e) the Drug Abuse Office and Treatment Act of 1972 (P.L. 92-255), as amended, relating to nondiscrimination on the basis of drug abuse; (f) the Comprehensive Alcohol Abuse and Alcoholism Prevention, Treatment and Rehabilitation Act of 1970 (P.L. 91-616), as amended, relating to nondiscrimination on the basis of alcohol abuse or alcoholism; (g) §§523 and 527 of the Public Health Service Act of 1912 (42 U.S.C. §§290 dd-3 and 290 ee 3), as amended, relating to confidentiality of alcohol and drug abuse patient records; (h) Title VIII of the Civil Rights Act of 1968 (42 U.S.C. §§3601 et seq.), as amended, relating to nondiscrimination in the sale, rental or financing of housing; (i) any other nondiscrimination provisions in the specific statute(s) under which application for Federal assistance is being made; and, (j) the requirements of any other nondiscrimination statute(s) which may apply to the application.

The equal opportunity clause provided under 41 CFR 60-1.4(b) is hereby incorporated by reference. Respondent agrees that such provision applies to any participating agency purchase or contract that meets the definition of "federally assisted construction contract" in 41 CFR Part 60-1.3 and Respondent agrees that it shall comply with such provision.

Davis Bacon Act and Copeland "Anti-Kickback" Act

When required by Federal program legislation, Respondent agrees that, for all participating agency contracts for the construction, alteration, or repair (including painting and decorating) of public buildings or public works, in excess of \$2,000, Respondent shall comply with the Davis-Bacon Act (40 U.S.C. 3141-3144, and 3146-3148) as supplemented by Department of Labor regulations (29 CFR Part 5, "Labor Standards Provisions Applicable to Contracts Covering Federally Financed and Assisted Construction"), the Copeland Act (40 U.S.C. §276c and 18 U.S.C. §874), and the Contract Work Hours and Safety Standards Act (40 U.S.C. §§327-333) regarding labor standards for federally-assisted construction sub agreements. In accordance with the statute, Respondent is required to pay wages to laborers and mechanics at a rate not less than the prevailing wages specific in a wage determinate made by the Secretary of Labor. Also, Respondent shall pay wages not less than once a week.

Current prevailing wage determinations issued by the Department of Labor are available at <https://sam.gov/content/wage-determinations>. Respondent agrees that, for any purchase to which this requirement applies, the award of the purchase to the Respondent is conditioned upon Respondent's acceptance of wage determination. As this Project is also subject to Washington Prevailing Wage requirements, Respondent and its Subcontractors of all tiers must pay the higher of the two wages (Prevailing and Davis-Bacon) when they are not the same.

Respondent further agrees that it shall also comply with the Copeland "Anti-Kickback" Act (40 U.S.C. 3145), as supplemented by Department of Labor regulations (29 CFR Part 3, "Contractors and Subcontractors on Public Building or Public Work Financed in Whole or in Part by Loans or Grants from the United States"). The Act provides that each construction completion, or repair of public work, to give up any part of the compensation to which he is otherwise entitled under his contract of employment, shall be defined under this titled or imprisoned not more than five (5) years, or both.

Contract Work Hours and Safety Standards Act

Where applicable, for all participating agency purchases in excess of \$100,000 that involve the employment of mechanics or laborers, Respondent shall comply with Sections 102 and 107 of the Contract Work Hours and Safety Standards Act (40 U.S.C. 327-333), as supplemented by Department of Labor regulations (29 CFR part 5). Under Section 102 of the Act, each contractor shall be required to compute the wages of every

mechanic and laborer on the basis of a standard work week of 40 hours. Work in excess of the standard work week is permissible provided that the worker is compensated at a rate of not less than 1 ½ times the basic rate of pay for all hours worked in excess of 40 hours in the work week. Section 107 of the Act is applicable to construction work and provides that no laborer or mechanic shall be required to work in the surroundings or under working conditions which are unsanitary, hazardous or dangerous. These requirements do not apply to the purchases of supplies or materials or articles ordinarily available on the open market, or contracts for transportation or transmission of intelligence.

Right to Inventions Made Under a Contract or Agreement

If the participating agency's federal award meets the definition of "funding agreement" under 37 CFR 401.2(a) and the recipient or sub-recipient wishes to enter into a contract with a small business firm or nonprofit organization regarding the substitution of parties, assignment or performance or experiments, developmental or research work under the "funding agreement," the recipient or sub-recipient must comply with the requirements of 37 CFR Part 401, "Rights to Inventions Made by Nonprofit Organizations and Small Business Firms Under Government Grants, Contracts and Cooperative Agreements," and any implementing regulations issued by the awarding agency.

Clean Air Act and Federal Water Pollution Control Act

Clean Air Act (42 U.S.C. 7401-7671q.) and the Federal Water Pollution Control Act (33 U.S.C. 1251-1387), as amended, contracts and subgrants of amounts in excess of \$150,000 must contain a provision that requires the non-Federal award to agree to comply with all applicable standards, orders, or regulations issued pursuant to the Clean Air Act (42 U.S.C. 7401-7671q.) and the Federal Water Pollution Control Act, as amended (33 U.S.C. 1251-1387). Violations must be reported to the Federal awarding agency and the Regional Office of the Environmental Protection Agency (EPA). When required, Respondent agrees to comply with all applicable standards, orders, or regulations issued pursuant to the Clean Air Act and the Federal Water Pollution Control Act.

Debarment and Suspension

Debarment and Suspension (Executive Orders 12549 and 12689), a contract award (see 2 CFR 180.222) must not be made to parties listed on the government-wide exclusions in the System for Award Management (SAM), in accordance with OMB guidelines at 2 CFR 180 that implement Executive Orders 12549 (3 CFR Part 1966 Comp. p. 189) and 12689 (3 CFR Part 1989 Comp. p. 235), "Debarment and Suspension." SAM exclusions contain the names of parties debarred, suspended, or otherwise excluded by agencies, as well as parties declared ineligible under statutory or regulatory authority other than Executive Order 12549. Respondent certifies that the Respondent is not currently listed and further agrees to immediately notify KCDA and all participating agencies with pending purchases or seeking to purchase from the Respondent if Respondent is later listed on the government-wide exclusions in SAM, or is debarred, suspended, or otherwise excluded by agencies or declared ineligible under state statutory or regulatory authority other than Executive Order 12549. Respondent will comply, and shall assist the Client and KCDA in complying, with the provisions of all applicable acts, regulations and assurances; the following provisions of Education Department General Administrative Regulations (EDGAR) 34 CFR parts 76, 77, 81, 82, 84, 97, 98, and 99; the OMB Guidelines to Agencies on Governmentwide Debarment and Suspension (Non procurement) in 2 CFR part 180, as adopted and amended as regulations of the Department in 2 CFR part 3485; and the Uniform Guidance in 2 CFR part 200, as adopted and amended as regulations of the Department in 2 CFR part 3474.

Byrd Anti-Lobbying Amendment

Byrd Anti-Lobbying Amendment (31 U.S.C. 1352), Respondents that apply or bid for an award exceeding \$100,000 must file the required certification. Each tier certifies to the tier above that it will not and has not used Federal appropriated funds to pay any person or organization for influencing or attempting to influence an officer or employee of any agency, a member of Congress, officer or employee of Congress, or an employee of a member of Congress in connection with obtaining any Federal contract, grant or any other award covered by 31 U.S.C. 1352. Each tier must also disclose any lobbying with non-Federal funds that take place in

connection with obtaining any Federal award. Such disclosures are forwarded from tier to tier up to the non-Federal award.

Procurement of Recovered Materials

For participating agency purchases utilizing Federal funds, Respondent agrees to comply with Section 6002 of the Solid Waste Disposal Act, as amended by the Resource Conservation and Recovery Act where applicable and provide such information and certifications as a participating agency may require to confirm estimates and otherwise comply. See 2 CFR 200.323. The requirements of Section 6002 include procuring only items designated in guidelines of the Environmental Protection Agency (EPA) at 40 CFR Part 247 that contain the highest percentage of recovered materials practicable, consistent with maintaining a satisfactory level of competition, where the purchase price of the item exceeds \$10,000 or the value of the quantity acquired during the preceding fiscal year exceeded \$10,000; procuring solid waste management services in a manner that maximizes energy and resource recovery, and establishing an affirmative procurement program for procurement of recovered materials identified in the EPA guidelines.

Profit as a Separate Element of Price

For purchases using federal funds in excess of \$250,000, a participating agency may be required to negotiate profit as a separate element of the price. See 2 CFR 200.324(b). When required by a participating agency, Respondent agrees to provide information and negotiate with the participating agency regarding profit as a separate element of the price for a particular purchase. However, Respondent agrees that the total price, including profit, charged by the Respondent to the participating agency shall not exceed the awarded pricing, including any applicable discount, under the Respondent's contract with KCDA.

General Compliance with Participating Agencies

In addition to the foregoing specific requirements, Respondent agrees, in accepting any purchase order from a participating agency, it shall make a good faith effort to work with a participating agency to provide such information and to satisfy requirements as may apply to a particular purchase or purchases including, but not limited to, applicable record keeping and record retention requirements as noted in the Federal Acquisition Regulation, FAR 4.703(a).

Bid #26-374, Bid Name – Bleachers, Auditorium Seating, and Other Equipment

**Attachment G - Uniform Guidance “EDGAR” Certification Form
2 CFR Part 200**

By initialing the table (1-12) and signing below, I certify that the information in this form is true, complete and accurate and that I am authorized by my business to make this certification and all consents and agreements contained herein.

Respondent Certification (By Item)	<u>Respondent Certification:</u> YES, I agree or NO, I do NOT agree	Initial
1. Violation of Contract Terms and Conditions		
2. Termination for Cause of Convenience		
3. Equal Employment Opportunity		
4. Davis-Bacon Act		
5. Contract Work Hours and Safety Standards Act		
6. Right to Inventions Made Under a Contract or Agreement		
7. Clean Air Act and Federal Water Pollution Control Act		
8. Debarment and Suspension		
9. Byrd Anti-Lobbying Amendment		
10. Procurement of Recovered Materials		
11. Profit as a Separate Element of Price		
12. General Compliance with Participating Agencies		

Name of Business

Signature of Authorized Representative

Printed Name

Date



Attachment H - Company Profile

IFB #26-374, Bleachers, Auditorium Seating, and Other Equipment

COMPANY CONTACT INFORMATION

Company Name: _____ Website: _____

Company Address: _____

City: _____ State: _____ Zip: _____

Contact Person: _____ Title: _____

Contact Phone: _____ Contact Email: _____

Washington State Department of Labor & Industries Contractor’s License No. _____

State of WA UBI No. _____

State of WA Employment Security Department No. _____

Washington State Excise Tax Registration No. _____

Federal Tax ID No. _____

SAM.gov – Unique Entity ID _____

BACKGROUND

Note: Generally, in high level contracts, KCDA will not accept an offer from a business that is less than five (5) years old or which fails to demonstrate and/or establish a proven record of business. If the bidder has recently purchased an established business or has proof of prior success in either this business or a closely related business, provide written documentation and verification in response to the questions below. KCDA reserves the right to accept or reject newly formed companies based on information provided in this response and from its own investigation of the company.

This business is a public company privately owned company.

In what year was this business started under its present name? _____

Under what other or former name(s) has your business operated? _____

Is this business a corporation? No Yes. If yes, please complete the following:

Date of incorporation: _____ State of incorporation: _____

Name of President: _____

Name(s) of Vice President(s): _____

Name of Secretary: _____

Name of Treasurer: _____

Is this business a partnership? No Yes. If yes, please complete the following:

Date of organization: _____ State founded: _____

Type of partnership, if applicable: _____

Name(s) of general partner(s): _____

Is this organization individually owned? No Yes. If yes, please complete the following:

Date of organization: _____ State founded: _____

Name of owner: _____

This organization is a form other than those identified above. No Yes.

IF THE ANSWER IS YES, describe the company's format, year and state of origin, and names and titles of the principals.

COMPANY HEADQUARTER LOCATION

Company Address: _____

City: _____ State: _____ Zip: _____

Main Phone Number: _____ How long at this address? _____

COMPANY BRANCH LOCATIONS

Branch Address: _____

City: _____ State: _____ Zip: _____

Branch Address: _____

City: _____ State: _____ Zip: _____

Branch Address: _____

City: _____ State: _____ Zip: _____

Branch Address: _____

City: _____ State: _____ Zip: _____

If more branch locations, insert information here or add another sheet with above information.

SALES HISTORY

Provide your company's annual sales for 2023, 2024 and 2025 in the United States by the various public segments:

	2023	2024	2025
K-12 (public & private), Educational Service Agencies	\$	\$	\$
Higher Education Institutions	\$	\$	\$
Counties, Cities, Townships, Villages	\$	\$	\$
States	\$	\$	\$
Other Public Sector & Non-profits	\$	\$	\$
Private Sector	\$	\$	\$
TOTAL	\$	\$	\$

WORK FORCE

1. **Key Contacts and Providers:** Provide a list of the individuals, titles, and contact information for the individuals who will provide the following services:

Function	Name	Title	Phone	Email
Contract Manager				
Sales Manager				
Customer & Support Manager				
Distributors, Dealers, Installers, Sales Reps				
Consultants & Trainers				
Technical, Maintenance & Support Services				
Quotes, Invoicing & Payments				
Warranty & After the Sale				
Financial Manager				

2. **Sales Force:** Provide total number and location of salespersons employed by your company in the states of Washington, Oregon, Idaho, Montana and Alaska by completing the following: *(To insert more rows, hit the tab key from the last field in the State column.)*

Number of Sales Reps	City	State

3. **Service/Support and Distribution Centers:** Provide the type (service/support or distribution) and location of centers that support the states of Washington, Oregon, Idaho, Montana and Alaska completing the following: *(To insert more rows, hit the tab key from the last field in the State column.)*

Center Type	City	State

4. **In-house Resources:** Describe the business’s current in-house workforce, equipment and facilities available to perform under this solicitation.

5. **Sales Training:** Explain how your company will educate your sales staff on the KCDA contract including timing, methods, etc.

ENVIRONMENTAL INITIATIVES

1. Describe how your products and/or services support environmental goals.

2. Describe the company’s “green” objectives (i.e. LEED, reducing footprint, etc.).

COOPERATIVE CONTRACTS

- 1. Does your company currently have contracts with other cooperatives (local, regional, state, national)? _____ YES _____ NO

If YES, identify which cooperatives and the respective expiration date(s).

If YES and your company is awarded a KCDA Contract, which contract will you lead with in marketing and sales representative presentations (sales calls)?

INDEPENDENT SUBCONTRACTORS, DISTRIBUTORS, INSTALLERS, ETC.

If the Bidder is not the sole manufacturer/provider of all goods and services provided under this contract, the following must be answered:

- 1. **Selection Criteria for Independent Providers:** Describe the criteria and process by which the business selects, certifies and approves subcontractors, distributors, installers and other independent services.

- 2. **Current Subcontractors, Distributors, Installers, Etc.:** Provide a list of current subcontractors, distributors, installers and other independent service providers who are contracted to perform the type of work outlined in this bid in the states of Washington, Oregon, Idaho, Montana and Alaska. Include, if applicable, contractor license information and the state(s) wherein they are eligible to provide services on behalf of this business.

DISCLOSURES

- 1. **Letter of Line of Credit or Annual Financial Report (REQUIRED):** Attach a letter from the business’s chief financial institution indicating the current line of credit available in its name and evidence of financial stability for the past three calendar years (2023, 2024 and 2025). This letter should state the line of credit as a range (i.e., “credit in the low six figures” or “a credit line exceeding five figures”). If company is a publicly traded company a complete Annual Financial Report is required in place of Line of Credit Letter.

- 2. **Legal:** Does this business have actions currently filed against it? No Yes.

IF YES, AN ATTACHMENT IS REQUIRED: List and explain current actions such as Federal Debarment (on US General Services Administration’s “Excluded Parties List”), appearance on any state or federal delinquent taxpayer list, or claims filed against the retainage and/or payment bond for projects.

REFERENCES

Provide contact information for your company’s largest public agency customers. (Minimum of 3 required).

Agency	Name	Title	Phone Number	Email
1.				
2.				
3.				
4.				
5.				

Signature _____
Must be same signature that appears on the bid response forms



**Attachment I -
Certification of Compliance with Wage Payment Statutes**

The bidder hereby certifies that, within the three-year period immediately preceding the bid solicitation date (April 24, 2026), the bidder is not a “willful” violator, as defined in RCW 49.48.082, of any provision of chapters 49.46, 49.48, or 49.52 RCW, as determined by a final and binding citation and notice of assessment issued by the Department of Labor and Industries or through a civil judgment entered by a court of limited or general jurisdiction.

I certify under penalty of perjury under the laws of the State of Washington that the foregoing is true and correct.

Bidder’s Business Name

Signature of Authorized Official*

Printed Name

Title

Date

City

State

Check One:

Sole Proprietorship General Partnership LLC Corporation

State of Incorporation, or if not a corporation, State where business entity was formed:

If a co-partnership, give firm name under which business is transacted:

** If a corporation, proposal must be executed in the corporate name by the president or vice-president (or any other corporate officer accompanied by evidence of authority to sign).
If a co-partnership, proposal must be executed by a partner.*

INVITATION FOR BIDS

BID #26-374, Bleachers, Auditorium, Other Equipment

Bleachers Indoor Telescoping Specifications

1.1 General Summary

Provide factory-fabricated, code-compliant telescoping gym bleachers including seating, structural frames, decking, rails, ADA provisions, curtains, and accessories.

- A. Section Includes: Telescoping Platform Seating includes, either manually or electrically operated systems of multiple-tiered seating rows comprising of seat, deck components, understructure that permits closing without requiring dismantling, into a nested configuration for storing or for moving purposes.
 - 1. Typical applications include the following:
 - a. Wall Attached Telescoping Platform Seats.
 - b. Recessed Telescoping Platform Seats.
 - c. Floor-Attached (Freestanding) Telescoping Platform Seats.
 - d. Portable/Movable Telescoping Platform Seats.
- B. Related Sections:
 - 1. Gym and or Athletic Flooring finishes for adequate floor & wall construction for operation of Telescoping Platform Seats. Flooring shall be level and rear wall plumb within 1/8" [3mm] in 8'-0 [2438mm]. Maximum Platform force on the floor, of a 19'6" [5944] section, shall be a static point load of less than 300 psi [2.48 N/mm²].
 - 2. Division 16 Type Electrical sections for electrical wiring and connections for electrically operated Telescoping Platform Seats.

1.2 Applicable Codes & Standards

- A) ICC 300-700 Standards for Bleachers, Folding, and Telescopic Seating and Grandstands
ICC A117.1 Standards for Accessible and Usable Buildings and Facilities
- B) ASCE 7-22 Minimum Design Loads and Associated Criteria for Buildings and other Structures
ASCE 7-22 Minimum Design Loads and Sesimic rating of the bleachers
- C) IBC Code as relates to current state building codes
IBC (Current WA Adoption)
- D) National Fire Protection Association (NFPA)
NFPA 102 Standard for Assembly Seating, Tents and Membrane Structures.
NFPA 70 National Electrical Code (NEC)
- E) American Welding society (AWS):
AWS D1.1 Structural Welding Code - Steel.
AWS D1.3 Structural Welding Code - Sheet Steel.
- F) American Institute of Steel Construction (AISC):
AISC - Design of Hot Rolled Steel Structural Members.
- G) American National Standards Institute (ANSI).
ANSI A117.1 Accessibility guidelines to accommodate individuals with

disabilities

ANSI / ASSE Z359.2 for fall protection and safety measures

ANSI / NSF 61 for materials used in bleacher construction to ensure

they are

safe for public use

Regularly inspect bleachers according to ANSI standards for structural integrity and maintenance.

Implement proper signage as per ANSI guidelines to inform users of safety protocols.

Train staff on ANSI safety standards to ensure proper usage and emergency procedures.

- H) American Iron & Steel Institute (AISI):
AISI - Design Cold Formed Steel Structural Members.
- I) Aluminum Association (AA):
AA - Aluminum Structures, Construction Manual Series.
- J) American Society for Testing Materials (ASTM):
ASTM - Standard Specification for Properties of Materials.
- K) National Forest Products Association (NFoPA):
NFOPA - National Design Specification for Wood Construction.
- L) Southern Pine Inspection Bureau (SPIB):
SPIB - Standard Grading Rules for Southern Pine.
- M) National Bureau of Standards/Products Standard (NBS/PS):
PS1 - Construction and Industrial Plywood.
- N) Americans with Disability Act (ADA)
ADA - Standards for Accessible Design.

1.3 System Requirements

- Wall- attached or Free standing
- Continuous deck, slip-resistant surface
- HDPE Benches or optional chair seating
- Aisles with rails & contrasting nosings
- ADA wheelchair / companion positions
- Seating Spacing- 22", 24", 26", 30", 32", 33"
- Rise- 10", 10 - 1/4", 11- 1/2", 11 5/8", 16"
- Footrest aisles w/intermediate aisle steps.
- Non – removable center hand rails/not to exceed the front edge of bleacher when stored.
- Panelam decking / poly coated plywood is not acceptable.
- All painted surfaces to be epoxy powder paint.
- Hinged first aisle step/ must be stored within the closed bleacher. 10.Recoverable ADA seating with guardrails on row above.
- Bleacher system must have a UL listing 12.UBC 97 or UBC 94 compliant

1.4 Material & Finishes

- Powder-coated steel frames
- UV-stable HDPE seats
- Corrosion-resistance hardware
- Lumber: ANSI/Voluntary Product 20, B & B Southern Pine
- Plywood: ANSI/Voluntary Product PS1, APA A-C Exterior Grade.
- Structural Steel Shapes, Plates and Bars: ASTM A 36.
- Uncoated Steel Strip (Non-Structural Components):
ASTM A569, Commercial Quality, Hot-Rolled Strip.
- Uncoated Steel Strip (Structural Components): ASTM A570 Grade 33, 40, 45, or 50, Structural Quality, Hot-

- Rolled Strip.
- Uncoated Steel Strip (Structural Components): ASTM A607 Grade 45 or 50, High-Strength, Low Alloy, Hot-Rolled Strip.
- Galvanized Steel Strip: ASTM A653 Grade 40, zinc coated by the hot-dip process, structural quality.
- Structural Tubing: ASTM A500 Grade B, cold-formed.
- Polyethylene Plastic: ASTM D 1248, Type III, Class B; molded, color-pigmented, textured, impact-resistant, structural formulation; in color indicated or, if not otherwise indicated, as selected by Architect from manufacturer's standard colors.
- Fasteners: Vibration-proof, of size and material standard with manufacturer.

1.5 MANUFACTURER'S SYSTEM ENGINEERING DESCRIPTION

- A) Structural Performance: Engineer, fabricate and install telescopic Platform seating systems to the following structural loads without exceeding allowable design working stresses of materials involved, including anchors and connections. Apply each load to produce maximum stress in each respective component of each Platform seat unit.
- Design Loads: Comply with NFPA 102, 1992 Edition, Chapter 5 for design loads.
- B) Manufacturer's System Design Criteria:
- Platform seat assembly; Design to support and resist, in addition to its own weight, the following forces:
 - Live load of 120 lbs per linear foot [162.69 N/m] on seats and decking
 - Uniformly distributed live load of not less than 100 lbs per sq. ft. [135.58N/m] of gross horizontal projection.
 - Parallel sway load of 24 lbs. per linear foot [32.53 N/m] of row.
 - Perpendicular sway load of 10 lbs. per linear foot [13.56 N-m] of row.
 - Hand Railings, Posts and Supports: Engineered to withstand the following forces applied separately:
 - Concentrated load of 200 lbs. [90.72 kg] applied at any point and in any direction.
 - Uniform load of 50 lbs. per foot [.344 N/mm²] applied in any direction.
 - Guard Railings, Post and Supports: Engineered to withstand the following forces applied separately:
 - Concentrated load of 200 lbs. [90.72 kg] applied at any point and in any direction along top rail.
 - Uniform load of 50 lbs. per foot [.344 N/mm²] applied horizontally at top rail and a simultaneous uniform load of 100 lbs. per foot [.689 N/mm²] applied vertically downward.
 - Member Sizes and Connections: Design criteria (current edition) of the following shall be the basis for calculation of member sizes and connections:
 - AISC: Manual of Steel Construction
 - AISI: Specification for Design of Cold Formed Steel Structural Members
 - AA: Specification for Aluminum Structures

- NFOPA: National Design Guide For Wood Construction

1.6 Motorized Operation (If provided)

- A) Integral Power: Furnish and install integral automatic electro-mechanical powered frame propulsion system, to open and close telescopic seating. Integral Power and Control System shall be Underwriters Laboratories, Inc. (UL) approved and listed.
- Operation shall be with a removable pendant control unit which plugs into seating bank for operator management of stop, start, forward, and reverse control of the power operation.
 - Each Powered Frame unit shall consist of output shaft gear reducer with 6" [152] diameter x 4" [102] wide wheels covered with non-marring 1/2" [13] thick composite rubber. Reducers shall be fitted with 3 phase induction motors which will provide an average operating speed of (46/25) f.p.m [.23/ .12 M/s].
 - Operating Loads: Each Powered Frame provides (220 / 550) lbs pull force [978 / 2446 N] which equals approximately (28 / 35) psi [.192 / .241 N/mm²] lateral force on the floor.
- B) Economy Integral Power: Furnish and install an integral automatic electro-mechanical powered frame propulsion system to open and close smaller telescopic seating sections up to 8 rows. Integral Power and Control System shall be Underwriters Laboratories, Inc. (UL) approved and listed
- Operation shall be with a removable pendant control unit which plugs into seating bank for operator management of stop, start, forward, and reverse control of the power operation.
 - Each Powered Frame unit shall consist of output shaft gear reducer with 6" [152] diameter x 4" [102] wide wheels covered with non-marring 1/2" [13] thick composite rubber. Reducers shall be fitted with single phase induction motors which will provide an average operating speed of 25 f.p.m [12 M/s].
 - Operating Loads: Each Powered Frame provides 280 lbs pull force [1245N] which equals approximately (30) psi [.206 N/mm²] lateral force on the floor.
 - Limit Switches: Furnish and install both open and closed limit switches for the integral power system. The limit switches will automatically stop integral power operation when seating has reached the fully extended or closed position.
 - Power operation shall utilize a combination of contactors and limit switches to insure the wiring is not energized except during operation. Straight wired electric system is not allowed.
 - Electrical: Seating Manufacturer shall provide all wiring within seating bank including pendant control.
 - Each unit for PF(1/2/3/4) is power operated by a 1/2 horsepower, 1725 R.P.M., 208 Volts, 50/60 Hz., three phase 1.25 service factor motor. This motor draws a full load current of 2.2 amperes. Power supply required shall be 120/208 volts three phase 5 wire plus ground service with 20 amps. Motors, housing, and

wiring shall be installed and grounded in complete accord with the National Electrical Code.

- Each unit for PFe is power operated by a 1/4 horsepower, 1725 R.P.M., 117 Volts, 60 Hz., single phase 1.1 service factor motor. This motor draws a full load current of 4.2 amperes. Power supply required shall be 120 volts single phase 2 wire plus ground service with 20 amps. Motors, housing, and wiring shall be installed and grounded in complete accord with the National Electrical Code
- The electrical contractor shall provide required power source with no greater than 4% voltage drop at the seatings' junction box. The electrical contractor shall perform all wiring connections in junction box that are attached to or a part of the building.

1.7 Seismic Anchorage

- WA-licensed PE stamped calculations

1.8 Installation

- A. Certified installers; testing & commissioning
- B. Manufacturer's Recommendations: Comply with telescoping Platform seats manufacturer's recommendations for product installation requirements.
- C. General: Install telescoping Platform seats in accordance with manufacturer's installation instructions and final shop drawings. Provide accessories, anchors, fasteners, inserts and other items for installation of telescoping Platform seats and for permanent attachment to adjoining construction.

1.9 Warranty

Manufacturer's Product Warranty: should comply with the manufacturer's warranty of the products mentioned for the telescoping or bleachers that will be bid on the contract.

Standards for warranty should be similar to following standards -

- Structural 10 yrs
- Electrical 2 yrs
- Finishes 3 yrs

ILLUSTRATED DIAGRAM OF BLEACHERS – TELESCOPING –

Telescoping Bleacher Diagram

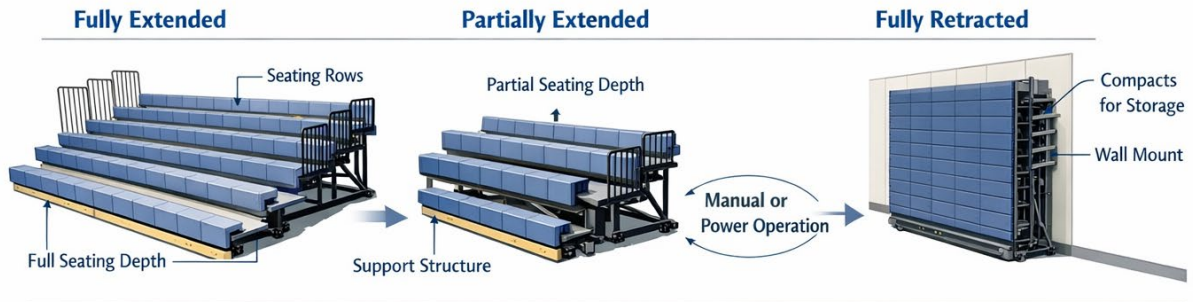

Detailed Breakdown

Seat & Riser Decks

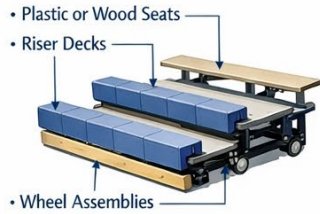

Guide Rails & Slide Mechanism

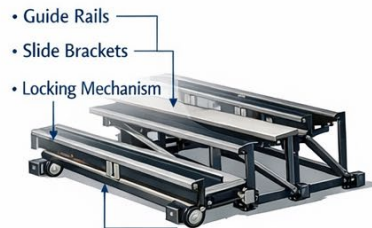

Support Structure



INVITATION FOR BIDS

BID #26-374, Bleachers, Auditorium Seating, and other equipment

OUTDOOR ALUMINUM FRAMED BLEACHER SPECIFICATIONS

1.1 General Summary

SCOPE

Design of the bleacher shall conform in all respects to the requirements as set forth in these specifications. The description of the bleacher is as follows:

Number of rows: 3, 5, AND 10
Overall length: 21'-0" OR 27'-0"

Provide factory – fabricated, code – compliant A36 alloy steel angle frame bleachers to provide additional seating near baseball, track field, and soccer fields in the region.

- A. Frames are fabricated from A36 alloy steel angles using full welds at all joints to give added strength. A combination of 2" x 2" x 3/16" and 1-3/4" x 1-3/4" x 3/16" angles are used, as required, for strength throughout each frame. Connecting "X" braces are 1-1/2" wide by 1/4" thick A36 alloy steel.
- B. For greatest protection and longest life, all parts are hot-dip galvanized after fabrication.

3 Lengths available: 15', 21' and 27'

3 Seat plank choices: Wood, Aluminum or Fiberglass seats

Frame choices: Aluminum angle and Galvanized Steel angle Foot planks are mill finish aluminum except units with wood seats, which come with wood foot planks.

1.2 Application Codes and Standards

- A. ASTM A36 - Specification for Structural Steel.
- B. ASTM A123 - Specification for Zinc (Hot-Dip Galvanized) Coatings on Iron and Steel Products.
- C. ASTM A307 - Specification for Carbon Steel Bolts and Studs, 60,000 psi Tensile.

1.3 UNDERSTRUCTURE

The understructure of the bleacher shall consist of a series of welded aluminum angle frames spaced at intervals of no more than 6'-0" and joined by means of aluminum sway braces, alloy 6061-T6, mill finish. Each frame shall consist of vertical members, adequate diagonal braces, and horizontal members welded to form an 8" rise on 5 and 10 row units (6" rise on 3 row units only) and a 24" back to back spacing between seat rows. All welded connections shall be by certified aluminum welders and all mating parts shall be welded on all sides to assure adequate strength.

1.4 DESIGN

The bleacher shall be designed to support, in addition to its own weight, a uniformly distributed live load of not less than 100 pounds per square foot of gross horizontal projection of the bleacher. All seat and foot plank members shall be designed to support not less than 120 pounds per lineal foot. The bleacher shall be designed to resist, with or without live load, a horizontal wind load appropriate for local conditions. It shall also be designed to resist, in addition to the live load, sway forces applied to the seats in a direction parallel to the length of the seat planks 24 pounds per lineal foot; and, in a direction perpendicular, stresses in aluminum members and connections shall not exceed those specified for Building Type Structures by the Aluminum Association.

1.5 SEATS AND DECKING

Seats shall be 2"x 10" nominal extruded (1.75"x9.5"actual) aluminum, alloy 6063-T6, wall thickness .078" (+/- .006" industry tolerance) with a raised fluted surface to provide a non-skid surface. Seats shall be anodized clear (204R1), conforming to the Aluminum Association Architectural Standard AA-C22A31. Seat planks shall have one internal support leg, and shall be designed to rest on a seat support with a minimum bearing surface of 8-1/2" to provide adequate resistance to torsion stress. Footboards shall consist of **two** 2"x10" nominal extruded (1.75"x9.5" actual) aluminum, alloy 6063-T6, wall thickness .078" (+/- .006" industry tolerance) with a raised fluted surface to provide a non-skid surface. Footboards shall have a mill finish. End caps provided for footboards shall match in both color and finish, shall be full length single piece, and shall attach by means of aluminum rivets on the underside of the plank. Rows 2 thru next to last row shall have a continuous 1 x 6 mill finished riser board and a 2 x 10 riser on last row.

Each bleacher unit shall have one (1) 60" wide vertical aisle with center handrail as required by UBC 97

End caps shall be of a heavy duty clamping, channel design, and shall match in both color and finish the plank to which they will attach. End caps shall be fastened to the underside by means of two aluminum rivets. Seats and footboards shall be connected to the supporting structure so as to transmit all live and sway loads to the understructure members, so placed to resist those loads specified in the design section. The connecting hardware (bolt clips) shall be of extruded aluminum, mill finish. Clips shall be so designed as to provide adjustability in four directions.

1.6 GUARDRAIL SYSTEM

Shall be a 2/3 aluminum lined rail system with 9 ga. **aluminized** chain link fabric on rear and sides to row 3 (no rails are required on 3 row bleachers only). Aluminum line rails (1-1/4" schedule 40) and fabric shall fasten to **aluminum channel** vertical supports as required. Galvanized vertical supports, lined rails or chain link fabric will not be allowed so as to prevent possibility of electrolysis.

1.7 HARDWARE

All structural hardware shall be 7/16" diameter, grade 5 machine bolts, complete with hex nuts and "spring type" lock washers. All hardware connecting plank to understructure shall be 5/16" diameter carriage bolts, complete with hex nuts and "spring type" lock washers. The finish of all hardware shall be either hot-dipped galvanized or stainless steel to prohibit deterioration from electrolysis. No other hardware finish will be considered as an alternate.

1.8 Design Loads:

Outdoor Bleachers should come with the following Design and Load restrictions to be safe.

1. Live Load: 100 psf gross horizontal projection.
2. Perpendicular Sway Load: 10 plf of seat plank.
3. Lateral Sway Load: 24 plf of seat plank.
4. Wind Load: 30 psf vertical projection.
5. Live Load for Seat and Tread Planks: 120 plf.
6. Guardrail Loads:
 - a. Vertical: 100 plf.
 - b. Horizontal: 50 plf.

1.9 QUALITY ASSURANCE

- A. Codes and Standards: Design, fabrication, and installation shall be in accordance with applicable codes, regulations, and handicap requirements. Owner will furnish local code requirements.
- B. Manufacturer Qualifications: Minimum 10 years experience in the design and manufacture of bleachers.
- C. Manufacturer Installed Qualifications: Employ persons trained and experienced in the installation of bleachers.
- D. Welders: AWS certified.

1.10 WARRANTY

All aluminum bleachers shall carry, after proper erection, and under normal use for this type of structure, a one (1) year warranty against all defects in materials and workmanship. Acts of vandalism or abuse shall render the conditions of this warranty null and void.

Illustration of Aluminum Outdoor Bleachers –

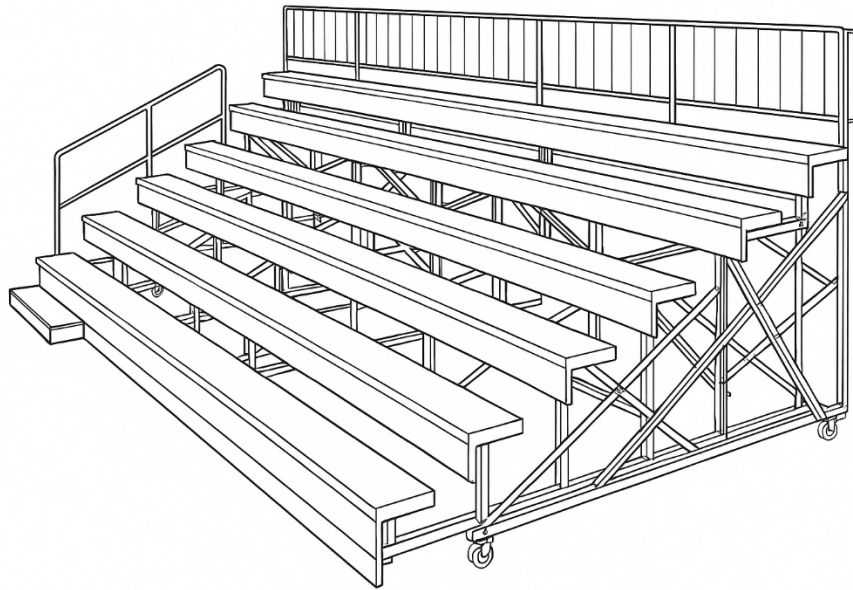

INVITATION FOR BIDS

AUDITORIUM SEATING Specifications Sheet BID #26-374

1.01 SUMMARY

Provide complete Fixed seating for auditorium including chairs permanent or movable frames, upholstery, labeling, ADA seating, and Accessories. Some types of these auditorium seating could be portable – removable or anchored to the auditorium setting floor.

- A. Section Includes: Fixed upholstered chairs with self-rising seat mechanisms, aisle and intermediate standards.
 - 1. Typical applications include the following:
 - a. Floor mounted chairs.
 - b. Riser mounted chairs.
- B. Related Sections:
 - 1. Division 16 Electrical sections for electrical wiring and connections for aisle lights.
- C. Alternates: This section specifies alternates for audience seating products. Refer to Part 2 products for alternate products, and to Division 1 Alternates sections and other bid documents, if any, for alternate requirements.
- D. Product Improvements: Hussey Seating Company strives to continuously improve its products and manufacturing methods. The company reserves the right to make changes without notice when, in the opinion of the company, such changes improve the product or its performance.
- E. Upholstered Seats:
 - 1. The seat assembly shall consist of a stylish padded and upholstered top surface, a polypropylene bottom shell with dual contours, and a dual sprung lifting mechanism. Seat shall have the ability to achieve a full fold position when rearward pressure is applied. Superior comfort shall be derived through careful ergonomic engineering.
 - 2. Upholstery Pad: The upholstered seat topper shall consist of a 5/8" thick formed ply form base with contoured molded polyurethane foam padding and fabric upholstered cover. Seat padding shall be properly contoured to support the body without causing discomfort. The upholstered seat cover shall exhibit a high degree of tailoring and will be affixed to the base with upholstery staples.
 - 3. Seat Mechanism: Seat lifting mechanism shall use lubricated lifting springs to provide whisper quiet fail-safe operation. The seat structure shall rotate on a 3/4" [19mm] spanner bar to assure shaft alignment and eliminate binding due to irregular floor conditions. Seats shall be certified to withstand 350,000 lifting cycles and a 600lb static load without failure.
 - 4. Standard Bottom Cover: Seat shell/bottom shall be constructed of polypropylene plastic to provide a durable yet aesthetic design. The cover

shall protect the mechanical parts of the lifting hinge and upholstered seat topper. The shell / bottom shape shall compliment the overall design of the chair.

5. Fully Enveloped Bottom Cover: Seat shell/bottom cover shall be constructed of polypropylene plastic covered with the specified upholstery laminated with foam for distinctive styling. Tailoring shall display a superior level of design workmanship and fit. Seams shall be straight, continuous and neat, without unsightly puckering.
6. **(Standard) Waterfall –(Optional) Quilted** (select quilt pattern I, II, III or IV), selection of standard 3” or plush 4” seat foam.

F. Classic Series Back (Plastic Outer Back Cover)

1. The outer back panel shall be constructed of injection molded polypropylene Plastic. The panel shall be no less than 27” in length and conceal the rear and sides of the upholstered inner panel. The panel shall extend below the rear of the seat to protect the chair occupant s back.
2. The inner upholstered panel shall be 5/8” (15mm) 11 ply thick-formed hardwood with an ergonomically engineered contour. The wings for attachment of chair back to standard shall be not less than 14 ga (1.9mm) and will be attached via concealed fasteners. Wings shall position the chair back at one of three positions: 15, 18, or 21 degrees. There shall be no exposed fasteners above the seat. Chair back upholstery shall exhibit a high degree of workmanship and customization.
3. Back Shape and Height:
 - a. Soft Square - 33”: The top corners of the back are conically shaped for stylish looks and a timeless appearance. Overall back height is 33” above the floor allowing proper shoulder support of the chair occupant. The back surface shall be compound contoured to facilitate proper posture of a seated individual.
 - b. Soft Square – 36” The top corners of the back are conically shaped for stylish looks and a timeless appearance. Overall back height is 36” above the floor allowing proper shoulder support of the chair occupant. The back surface shall be compound contoured to facilitate proper posture of a seated individual.
 - c. Round – 33” The top of the back is radiused for stylish looks and a timeless appearance. Overall back height is 33” above the floor allowing proper shoulder support of the chair occupant. The back surface shall be compound contoured to facilitate proper posture of a seated individual.
 - d. Round – 36” The top of the back is radiused for stylish looks and a timeless appearance. Overall back height is 36” above the floor allowing proper shoulder support of the chair occupant. The back surface shall be compound contoured to facilitate proper posture of a seated individual.
4. **Back Foam Type:** 2”(51mm)cut, 3”(76mm)cut, Contoured Foam.
5. **BACK COVER TAILORING.** Waterfall, Horizontal Pleat, Quilt -I, Quilt - II, Quilt - III, Quilt-IV.

G. Designer Series Back (Wood Veneer or Laminate Outer Back Panel)

1. The outer back panel shall be constructed of hardwood inner veneers with a decorative wood veneer or high pressure laminate outer layer. The panel shall be no less than 27" in length with a fabric welt cold to conceal any gaps between the inner and outer panels and protect the panel edge from damage. The panel shall extend below the rear of the seat to protect the chair occupant s back.
2. The inner upholstered panel shall be 5/8" (15mm) 11 ply thick-formed hardwood with an ergonomically engineered contour. The wings for attachment of chair back to standard shall be not less than 14 ga (1.9mm) and will be attached via concealed fasteners. Wings shall position the chair back at one of three positions: 15, 18, or 21 degrees. There shall be no exposed fasteners above the seat. Chair back upholstery shall exhibit a high degree of workmanship and customization.
3. BACK SHAPE AND HEIGHT:
 - a. Soft Square - 33": The top corners of the back are conically shaped for stylish looks and a timeless appearance. Overall back height is 33" above the floor allowing proper shoulder support of the chair occupant. The back surface shall be compound contoured to facilitate proper posture of a seated individual.
 - b. Soft Square – 36" The top corners of the back are conically shaped for stylish looks and a timeless appearance. Overall back height is 36" above the floor allowing proper shoulder support of the chair occupant. The back surface shall be compound contoured to facilitate proper posture of a seated individual.
 - c. Round – 33" The top of the back is radiused for stylish looks and a timeless appearance. Overall back height is 33" above the floor allowing proper shoulder support of the chair occupant. The back surface shall be compound contoured to facilitate proper posture of a seated individual.
 - d. Round – 36" The top of the back is radiused for stylish looks and a timeless appearance. Overall back height is 36" above the floor allowing proper shoulder support of the chair occupant. The back surface shall be compound contoured to facilitate proper posture of a seated individual.

H. Soft SideSeries Back (Upholstered Outer Back Panel)

1. The outer back panel shall be constructed of a hardwood plyform panel covered with the specified upholstery fabric for distinctive styling. The panel shall be no less than 27" in length with a fabric welt cold to conceal any gaps between the inner and outer panels and protect the panel edge from damage. The panel shall extend below the rear of the seat to protect the chair occupant s back.
2. The inner upholstered panel shall be 5/8" (15mm) 11 ply thick-formed hardwood with an ergonomically engineered contour. The wings for attachment of chair back to standard shall be not less than 14 ga (1.9mm) and will be attached via concealed fasteners. Wings shall position the chair back at one of three positions: 15, 18, or 21 degrees. There shall be no

exposed fasteners above the seat. Chair back upholstery shall exhibit a high degree of workmanship and customization.

3. BACK SHAPE AND HEIGHT:

- a. Soft Square - 33": The top corners of the back are conically shaped for stylish looks and a timeless appearance. Overall back height is 33" above the floor allowing proper shoulder support of the chair occupant. The back surface shall be compound contoured to facilitate proper posture of a seated individual.
- b. Soft Square – 36" The top corners of the back are conically shaped for stylish looks and a timeless appearance. Overall back height is 36" above the floor allowing proper shoulder support of the chair occupant. The back surface shall be compound contoured to facilitate proper posture of a seated individual.
- c. Round – 33" The top of the back is radiused for stylish looks and a timeless appearance. Overall back height is 33" above the floor allowing proper shoulder support of the chair occupant. The back surface shall be compound contoured to facilitate proper posture of a seated individual.
- d. Round – 36" The top of the back is radiused for stylish looks and a timeless appearance. Overall back height is 36" above the floor allowing proper shoulder support of the chair occupant. The back surface shall be compound contoured to facilitate proper posture of a seated individual.

1.02 Applicable Codes & Standards:

- A. American Welding society (AWS):
 1. AWS D1.1 Structural Welding Code - Steel.
 2. AWS D1.3 Structural Welding Code - Sheet Steel.
- B. American Institute of Steel Construction (AISC):
 1. AISC - Design of Hot Rolled Steel Structural Members.
- C. American National Standards Institute (ANSI).
- D. American Iron & Steel Institute (AISI):
 1. AISI - Design Cold Formed Steel Structural Members.
- E. Aluminum Association (AA):
 1. AA - Aluminum Structures, Construction Manual Series.
- F. American Society for Testing Materials (ASTM)
 1. ASTM - Standard Specification for Properties of Materials.
- G. National Forest Products Association (NFPA):
 1. NFPA - National Design Specification for Wood Construction.
- H. National Bureau of Standards/Products Standard (NBS/PS):
 1. PS1 - Construction and Industrial Plywood.
- I. Americans with Disability Act (ADA)
 1. ADA - Standards for Accessible Design.

1.03 Seating Requirement

- Tip-up seats with quiet return
- Width 19–22 inches
- Row spacing \geq 34 inches
- Fabric or vinyl upholstery, 100,000 double rubs
- Aisle lights optional

1.04 Materials & Construction

Injection molded or laminated cores
 High-density polyurethane foam
 Powder-coated steel/aluminum frames

- Cast Aluminum: AA - 380
- Steel Tubing: ASTM A513
- Steel Sheet/Coil: ASTM A607
- Mechanical or Adhesive Concrete Anchors: SAE grade 2
- Exposed Hardwood Lumber: Wood Species: Birch
- Concealed Plywood: Engineered Wood Association PS1-95 2000: Poplar
- Exposed Plywood: Hardwood Plywood ANSI/HPVA-1 2000: Birch
- Medium Density Fiberboard: ANSI A208-2-1986
- Plastic Laminate: NEMA LD3.1-1985, GP 48
- Polyurethane Foam Padding: ASTM D-3574
 - Fabric: 100% Marquesa Lana continuous filament Olefin in the following standard selections:
 - Fabric shall have 13 fill picks per inch, 13 warp ends per inch, weighing 16 oz. [454grams] per linear yard including backing.
 - Fabric shall have 13 fill picks per inch, 13 warp ends per inch, weighing 18 oz. [510grams] per linear yard including backing.
 - Fabric shall have 16 fill picks per inch, 19 warp ends per inch, weighing 12 oz. [340grams] per linear yard including backing.
- Molded plastic: Injection Molded copolymer polypropylene or nylon 6/6.
- Materials (Flammability) shall satisfy applicable test, codes, standards, or requirements as follows:
 - Copolymer polypropylene shall have a burn rate of 1 inch [25.4mm] or less per ASTM 635.
 - Upholstery materials shall meet requirements as set forth in the state of California Bureau of Home Furnishings Technical Bulletin 117.
 - Fire-performance Characteristics of Seat Padding: Provide seating that complies with test method: California Technical Bulletin 117
 - Cushioning and padding shall be self-extinguishing as defined in the requirements as set forth in the State of California Bureau of Home Furnishings Technical Bulletin 117.
 - Full Scale Fire Performance Characteristics of Finished Chair: Provide seating that complies with test method: California Technical Bulletin 133 or British Standard CRIB 5

1.05 Installation

Anchored to slab with engineered layout

A. Steel Standards:

1. Standards shall be 1"[25mm] x 3"[76mm] x 16 gauge[1.5mm] seamless oval mechanical tubing. Standards utilizing an open seam (not welded) shall be considered unacceptable.
2. The top of the standard shall provide for vandal resistant attachment of the armrest, without the use of exposed fasteners on the surface of the arm.
3. **FLOOR MOUNTED STANDARDS** Floor mounted standards shall have a 14 gauge [1.9mm] formed steel foot. The formed foot shall be full perimeter welded to the upright tubular member. The floor mount standards shall be manufactured to match floor inclines in order to maintain proper seat height and angle.
4. **RISER MOUNTED STANDARDS** Riser mounted standards shall have a 7 gauge [4.5mm] steel plate slotted to allow lateral adjustment during installation, and shall be full perimeter welded to the tubular standards.

B. Cast Aluminum Standards:

1. Standards shall be die cast Aluminum AA380 grade.
2. **FLOOR MOUNT STANDARDS** Standards shall be floor attached, designed to maintain a constant seat height to floor.
3. **RISER MOUNT STANDARDS** Standards shall be riser attached.
4. Cast Aluminum Standards shall be an integral aesthetic part of the chair's appearance and do not require the use of end panels.

C. Seat Hinges:

1. Seat hinges shall be fully contained within the seat pan and fitted with a pair of independent, permanently lubricated bearings.
2. Each of the independent seat hinges shall be fitted with double acting; self-centering, pre-loaded coiled seat return springs.
3. Seat hinge and spring installation shall be designed not to require periodic adjustment or lubrication.

D. Finish:

1. Finish for Steel / Aluminum Components: (Indoor) Material shall be pre-treated in an iron phosphate wash system prior to finish application. Finish shall be a specially blended polyester T.G.I.C./Epoxy powder coating with a minimum dry film thickness of 1.5 mils.
2. Injection molded polypropylene or nylon: Shall be pigmented, in one of manufacturers standard colors and have a textured surface.
3. Fabric: Upholstery material shall be 100% Marquesa Lana continuous filament Olefin yarn with one of manufacturer's standard fabric offerings.
4. Color: Shall be per manufacturer's standards. Seating Contractor shall submit color samples for owner's approval prior to manufacture.

1.06 MANUFACTURER'S SYSTEM ENGINEERING DESCRIPTION

- A. Structural Performance: Engineer, fabricate and install fixed audience seating to the following structural loads without exceeding allowable design working stresses of materials involved, including anchors and connection. Apply each load to produce maximum stress in each respective component of each audience seat unit.
- B. Manufacturer's System Design Criteria:
1. Seats and Backs:
 - a. Shall embody a timeless sculptured appearance to harmonize with any architectural form or room decor.
 - b. Shall exhibit moderate compound contours for supportive comfort avoiding excess anatomical pressures.
 - c. Seat shall be semi-cantilevered, self-centering, automatic three-quarter (3/4) lift with over center retract feature, for ease of passage and janitorial access.
 - d. Seat shall be tested and professionally certified through an independent testing laboratory to support and withstand an evenly distributed 600 lb.[272 Kg] static load without failure or irregularities that would impair usefulness.
 - e. Self-lifting seat shall be tested and professionally certified through an independent testing laboratory to withstand 350,000 operating cycles without failure of seat mechanism or measurable component wear.
 - f. Seat shall be tested and professionally certified to withstand 10,000 impacts of a 40 lb.[18 Kg] sandbag dropped on the center of the seat from each of the following heights: 6"[152mm], 8"[203mm], 10"[254mm], and 12"[305mm]. The rate of impacts shall be approximately 18 per minute with the total quantity of impacts equaling 40,000.
 - g. Back shall withstand an evenly distributed front or rear static load of 450 lbs.[205 Kg].
 - h. Back shall be tested and professionally certified to withstand, without failure, 40,000 swinging impacts each to the front and rear of the back by means of two opposing 40 lb. [18 Kg] sandbags. The sandbags shall be moved horizontally and equally for 10,000 cycles each at the following distances of 6"[152mm], 8"[203mm], 10"[254mm], and 12"[305mm] at a rate of 35 cycles per minute.
 - i. Back shall withstand, without failure, an evenly distributed Horizontal Traverse Static Load of 200 lbs.[90.70Kg]. The load shall be applied to the top of the back at a 45-degree angle to the row of seats.
 - j. Armrests shall be tested and professionally certified to withstand, without failure, a 200 lb.[91 Kg] static load applied both perpendicular to and vertically down on the arm.

1.07 DESIGN AND CONCEPT:

Auditorium chairs shall be designed to exhibit a modern appearance that will enhance any auditorium's décor. Seats, backs, and standards shall complement each other without the need for end panels or other adornments. Superior comfort will be derived through careful ergonomic engineering, selection of materials, and design of supportive structures.

1.08 FASTENINGS

A. Chair Assembly

1. All welds shall be made at the factory by welders that are certified on the equipment and process used.
2. All structural connections shall be made with S.A.E. stress rated zinc plated or, black oxide steel bolts, washers and nuts.

B. Concrete Floor Attachment

1. Chair stanchions shall each be attached by means of two 1/4"[6mm] mechanical wedge anchors set in holes drilled to a minimum depth of 2"[50mm] in the concrete.
 - a. Wedge anchors shall be tested to ASTM E488 criteria and listed by ICBO and SBCCI. Wedge anchors feature a type 18-8 stainless steel split expansion ring and a threaded stud bolt body and integral cone expander, and a nut and washers. Stanchion shall be placed on the bolts, stanchions to be permanently secured with a flat washer, lock washer and nut.

B. Concrete Riser Attachment

1. Chair stanchions shall each be attached by means of two 3/8"[10mm] threaded rods secured into concrete with a fast curing acrylic adhesive. Adhesive and rods are set in holes drilled to a minimum depth of 2 1/2"[64mm] in the concrete.
2. Threaded rods shall be of approved type with zinc-plate finish or made of stainless steel to suit environmental conditions.
3. Acrylic Adhesive shall be in conformance with ASTM Type IV, Grade 3, and covered by ICBO evaluation.
4. Stanchion to be placed on the bolts, stanchions to be permanently secured with a flat washer, lock washer and nut.

C. Wood Floor Attachment.

1. Chair standards shall each be attached by means of four (4) 1/4 inch [6mm] x 1 3/4 inch [44mm] lag screws and flat washer set in holes drilled to a depth of not less than 1 1/2 inches [38mm] in the wood.

1.09 QUALITY ASSURANCE

A. Welding Standards & Qualification: Comply with AWS D1.1 Structural Welding Code - Steel and AWS D1.3 Structural Welding Code - Sheet Steel.

B. Insurance Qualifications: Mandatory that each bidder submit with his bid an insurance certificate from the manufacturer evidencing the following insurance coverage:

1. Workers Compensation - including Employers Liability with the following limits:
 - a. \$500,000.00 Each Accident
 - b. \$500,000.00 Disease - Policy Limit
 - c. \$500,000.00 Disease - Each Employee
2. Commercial General Liability - including premises/ operations, independent contractors and products completed operations liability. Limits of liability shall not be less than \$2,000,000.00

- C. Manufacturer Qualifications: Manufacturer who has 10 years of experience manufacturing spectator seating equipment.
- D. Installer Qualifications: Engage experienced Installer who has specialized in installation of audience seating similar to types required for this project and who is acceptable to, or certified by, fixed upholstered chair seating manufacturer.
- E. Engineer Qualifications: Engage professional licensed engineer experienced in providing engineering services of the kind indicated that have resulted in the successful installation of audience seating similar in material, design, fabrication, and extent to those types indicated for this project.

1.10 DELIVERY, STORAGE AND HANDLING

- A. Deliver fixed upholstered chair seating in manufacturers packaging clearly labeled with manufacturer name and content.
- B. Handle seating equipment in a manner to prevent damage.
- C. Deliver the seating at a scheduled time for installation that will not interfere with other trades operating in the building.

1.11 PROJECT CONDITIONS

- A. Field Measurements: Coordinate actual dimensions of construction affecting fixed upholstered chair seating installation by accurate field measurements before fabrication. Show recorded measurements on final shop drawings. Coordinate field measurements and fabrication schedule with construction progress to avoid delay of Work.

1.12 MAINTENANCE AND OPERATION

- A. Instructions: An owners manual shall be transmitted to the Owner by the manufacturer of the seating or his representative.
- B. Service: Maintenance and operation of the seating system shall be the responsibility of the Owner or his duly authorized representative, and shall include the following:
 - 1. Only attachments specifically approved by the manufacturer for the specific installation shall be attached to the seating.
 - 2. Periodic annual inspections and required maintenance of each seating system shall be performed according to the owners manual to assure safe conditions.

1.13 Auditorium Seating Accessories Details – Armrests / Cupholders / Etc:

- 1. Armrests, Injection Molded Plastic: Armrests shall be of injection molded, textured polypropylene. Armrest to be secured to standard with concealed fasteners.
- 2. Armrests, Stained Hardwood: Armrests shall be solid hardwood without defects. All edges shall be eased for comfort. Armrest finish shall consist of a single coat of waterbase stain, followed by a sealer coat, scuff sanding, and a waterbase clear topcoat. Stain shall be selected from manufacturer's standard offerings. Armrest to be secured to standard with concealed fasteners.

3. Armrests, Painted Hardwood: Armrests shall be solid hardwood without defects. All edges shall be eased for comfort. Armrest finish shall consist of two coats of waterbase paint with scuff sanding between coats, followed by a waterbase clear top coat. Paint shall be selected from manufacturer's standard offerings. Armrest to be secured to standard with concealed fasteners.
4. Armrests, Upholstered: Armrests shall be tempered hardboard core with polyurethane foam padding and covered with matching upholstery fabric. Armrest to be secured to standard with concealed fasteners.
 - A. Armrest, Easy Access: Armrest shall hinge on end standards to allow easy access for disabled patrons. Swing-up end arms shall be provided for one percent of fixed seating capacity to meet the Americans with Disabilities Act (ADA). Each accessible chair shall include the universal handicap symbol on the end aisle standard for clear identification.
 - B. Standard, Armless: Aisle end stanchion shall have armrest removed and replaced with an injection molded plastic cover to hide back mounting hardware. Armless stanchions allow easy access for disabled patrons. Armless end stanchions shall be provided for one percent of fixed seating capacity to meet the Americans with Disabilities Act (ADA). Each accessible chair shall include the universal handicap symbol on the aisle standard for clear identification and is located in a vandal resistant recess and is secured with adhesive.
5. Cupholder Accessories Details:
 - A. Cupholder Armrest, Plastic: Armrest with integral molded cupholder made of injection molded nylon with textured plastic arm surface.
 - B. Cupholder Armrest, Upholstered: Armrest with integral molded cupholder made of injection-molded nylon with an upholstered armrest surface.
 - C. Cupholder Armrest, Solid Hardwood: Armrest with integral molded cupholder made of injection-molded nylon with a solid hardwood armrest surface.
6. End Panels Accessories Details:
 - A. End Panels, Plastic Laminate: End panels to be 1/2"[13mm] MDF, finished with laminated plastic. End panels to be furnished per Plan of Seating.
 - B. End Panels, Veneer: End panels to be 1/2"[13mm] MDF, finished with wood veneer. End panels to be furnished per Plan of Seating.
 - C. End Panels, Upholstered: End panels to be 1/2"[13mm] MDF, with upholstered finish. End panels to be furnished per Plan of Seating.

7. Chair Numbers Accessories Details:

- A. Standard Chair Numbers: Black text with gray background on a $2\frac{3}{32}$ " x $2\frac{7}{32}$ " [18.5mm x 56.5mm] elliptical Lexan plate. Plate fitted in a vandal resistant recess located in rear of armrest and secured with adhesive.
- B. Aluminum Chair Numbers: Black text with gray background on a $2\frac{3}{32}$ " x $2\frac{7}{32}$ " [18.5mm x 56.5mm] elliptical aluminum plate. Plate fitted in a vandal resistant recess located in rear of armrest and secured with two aluminum pop rivets.
- C. ECOGLO Chair Numbers: Black text with pale green background on a $2\frac{3}{32}$ " x $2\frac{7}{32}$ " [18.5mm x 56.5mm] elliptical Aluminum plate with photo luminous coating. Plate fitted in vandal resistant recess located in front edge of seat pan and secured with two aluminum pop rivets.
- D. Standard Row Letters: Black text with gray background on a $2\frac{3}{32}$ " x $2\frac{7}{32}$ " [18.5mm x 56.5mm] elliptical Lexan plate. Plate fitted in a vandal resistant recess located in rear of armrest and secured with adhesive.
- E. Aluminum Row Letters: Black text with gray background on a $2\frac{3}{32}$ " x $2\frac{7}{32}$ " [18.5mm x 56.5mm] elliptical aluminum plate. Plate fitted in a vandal resistant recess located in rear of armrest and secured with aluminum pop rivets.
- F. ECOGLO Row Letters: Black text with pale green background on a $2\frac{3}{32}$ " x $2\frac{7}{32}$ " [18.5mm x 56.5mm] elliptical Aluminum plate with photo luminous coating. Plate fitted in a vandal resistant recess located in rear of armrest and secured with two aluminum pop rivets.
- G. Donor Plate: $\frac{7}{8}$ " x 3" [22mm x 76mm] oval shaped Brass plate. Plate fitted in a vandal resistant recess located in the front of armrest and.
- H. ECOGLO Donor Plate: $\frac{7}{8}$ " x 3" [22mm x 76mm] oval shaped Aluminum plate with pale green photo luminous coating. Plate fitted in a vandal resistant recess located in the front of armrest and secured with adhesive.
- I. T1 Folding Tablet Arm: Tablet arm to be $11\frac{3}{4}$ " x $10\frac{1}{4}$ " [298mm x 260mm] square with rounded corners. Top and bottom surfaces to be high pressure laminate over solid core plywood. Tablet arm to store within users' chair beneath the armrest.
- J. T2 Folding Laptop Tablet Arm: Tablet arm to be $18\frac{7}{8}$ " x $15\frac{3}{4}$ " [480mm x 400mm] square with rounded corners. Top and bottom surfaces to be high pressure laminate over solid core plywood. Tablet arm to store within users' chair beneath the seat.

- K. T2m Folding Laptop Tablet Arm for reduced row spacing: Tablet arm to be 18 7/8" x 12 1/2" [480mm x 320mm] square with rounded corners. Top and bottom surfaces to be high pressure laminate over solid core plywood. Tablet arm to store within users' chair beneath the seat.
- L. Cast Logo: Logo to be 6" [150mm] circle and manufactured of die-cast aluminum or zinc. Logo secured to the stanchion with tamper-proof hardware.
- M. Graphic Logo: Logo to be 6" [150mm] circle and manufactured of 0.5mm thick vinyl. Logo secured to the stanchion with self-adhesive backing.
- N. Quick-Link System : Power or Power and Data connections integrated into the design of the chair with the ability to be added at a later date without disassembly to existing chairs.

8. Removable Chair Details:

- A. Removable Chairs: Provide chairs to be floor mounted and ganged in groups of one, two, or three chair units for easy removal. Chair standards shall be mounted to a painted steel skid base. Skid base with chairs shall be easily removed from the concrete floor by means of flush mounted internally threaded expansion anchors positioned under each leg of the skid. When removed, the anchor holes are filled by flat head bolts to provide a flat surface and prevent dirt and debris from entering.

9. Aisle Lights , Worship Organizer, Custom Wood Pew Accessories Details:

- A. Aisle Lights: Aisle lights will operate from 24 volts (low voltage) requiring a transformer system (supplied by Hussey). "Low Voltage Luminaire" electrical system approved by Underwriters Laboratories Inc. Aisle lights to be mounted onto end panel or aisle standard and will be furnished with cover as an integral part of the chair standard.
- B. Worship Organizer I: Provide a durable organizer capable of holding a worship book(s). The design shall include additional compartments for convenient storage of other items such as communion cups, pamphlets, envelopes and pens. The organizer shall mount securely to the rear of the chair back or pew in a manner so it will not project into the aisle space. Include as an option the ability to add a custom message or symbol in a visible location on the organizer.
- C. Worship Organizer II: Provide a durable organizer with compartments for holding pen/pencils, communion cups, envelopes and pamphlets. The organizer shall mount securely to the rear of the chair back or pew in a manner so it will not project into the aisle space. Include as an option the ability to add a custom message or symbol in a visible location on the organizer.
- D. Custom Wood Pew End: Provide a decorative wood panel at the end of each row of chairs to create the appearance of

traditional pew seating along the sides of the aisle. Design shall conceal the chair supports and fasteners without impeding on the egress space between seating rows. Include as an option the ability to add a custom shape or symbol on the aisle side of the panel.

1.14 Warranty :

Manufacturer's Product Warranty: Submit manufacturer's standard warranty form for fixed upholstered chairs. This warranty is in addition to, and not a limitation of other rights Owner may have under Contract Documents.

Standard Warranty Term on Auditorium Seating -

Warranty Structure 10 yrs

Warranty for upholstery 5 yrs

Warranty for mechanical 5 yrs

Illustration of Auditorium Seating –

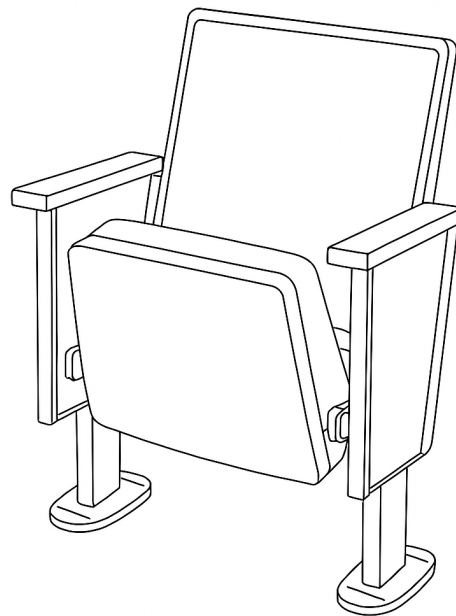

Invitation for Bids
BID #26-374, Bleachers, Auditorium Seating, and other equipment

Outdoor Stadium with Press Box Specification Sheet

1.1 General Summary

Scope of Work:

Provide all labor, materials, equipment, engineering, and supervision necessary to furnish and install a complete outdoor stadium seating system with integrated press box.

1.2 Quality Assurance:

Manufacturer must have a minimum of 10 years experience; installer must be certified.

1.3 Stadium Structure:

Vendor or Manufacturer should provide a statement of what they can provide to meet the best seating capacity by reference or range of seats that they can provide on this bid.

Materials: Manufacturer should provide a statement how the outdoor seating structure will be built by describing the materials that will be used. Will be a cement stadium structure or be made of aluminum or galvanized steel frames; slip-resistant aluminum decking; guardrails per IBC.

Foundation: Vendor or Manufacturer will provide a statement explaining how the stadium will be build whether it will be a concrete slab or pier footings engineered for site. Also indicate the Accesibility for being ADA-complaint for wheelchair spaces and access routes.

1.4 Design:

The outdoor stadium bleacher shall be designed to support, in addition to its own weight, a uniformly distributed live load of not less than 100 pounds per square foot of gross horizontal projection of the bleacher. All seat and foot plank members shall be designed to support not less than 120 pounds per lineal foot. The bleacher shall be designed to resist, with or without live load, a horizontal wind load appropriate for local conditions. It shall also be designed to resist, in addition to the live load, sway forces applied to the seats in a direction parallel to the length of the seat planks 24 pounds per lineal foot; and, in a direction perpendicular, stresses in aluminum members and connections shall not exceed those specified for Building Type Structures by the Aluminum Association. Some design would not be considered important if the outdoor stadium proposed is

constructed of cement or has solid foundation underneath the seating and press box area as part of the design.

1.5. Press Box Requirements:

Vendor or Manufacturer will describe the Dimensions: ___ ft x ___ ft x ___ ft that they can provide or build for a press box. Provide a statement on construction of the press box and will it include insulated walls, tempered glass windows, locking doors, and what other things.

Electrical: Description on types of electrical that would be provided to the press box such as dedicated circuits, outlets, and LED lighting. Also including the type of technology features would be included such as conduits for data, PA system provisions, and etc.

HVAC: Description of the heating or Mini-split or baseboard heat with ventilation that could be provided in the press box as it was built.

1.6 Access & Egress

Manufacturer or Vendor will provide specs to the Aluminum or steel stair system with handrails that will be associated with Outdoor stadium construction. Also will indicate any optional exterior platforms that will be provided within the structure too.

1.7 Safety & Code Compliance

Must meet IBC, NFPA, ADA, and seismic requirements for Washington State.

1.8 Options

Manufacturer could provide accessory support for Sound System positioning, scoreboard integration, stadium lighting, ADA Lift enhancement, storage, and or branding. If scoreboard or stadium lighting is to be considered in be incorporated with a KCDA or AEPA contract that is under contract.

1.9 Submittals

Manufacturer or vendor will provide product data sheets, shop drawings, stamp engineering calcs, and etc when drafting a proposal for customers. The proposal for an outdoor stadium should match the warranty for the product and have assigned schedule to move forward.

1.10 Warranty

Manufacturer or Vendor should warranty that would be at least 5 year from the manufacturer and 1 year workmanship of building the stadium.

Illustration of Outdoor Stadium Bleachers and Press Box :

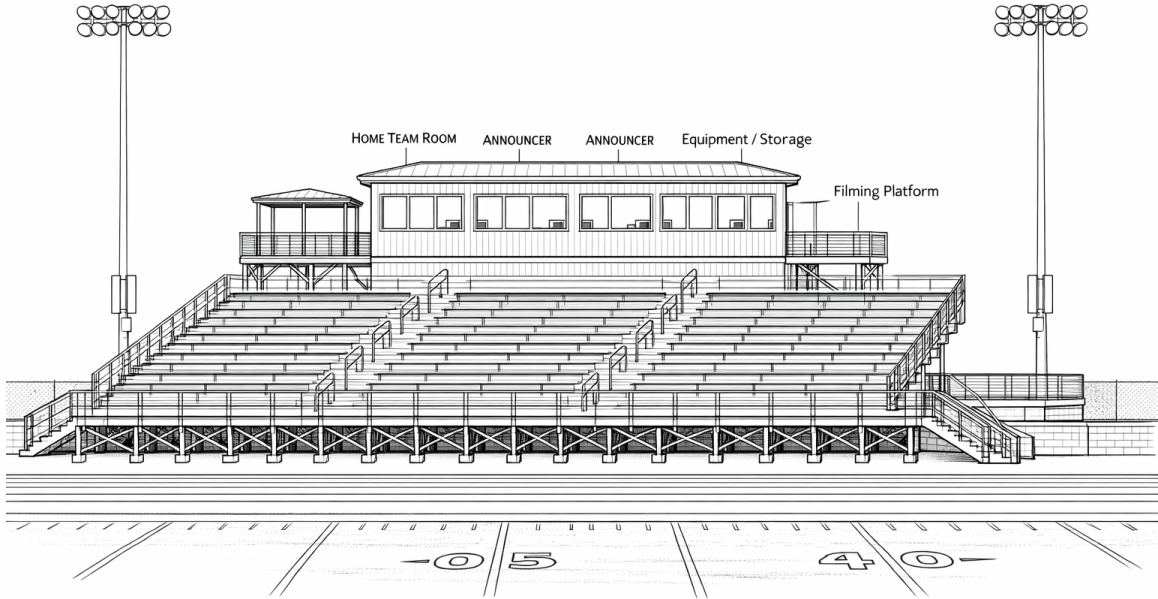

Invitation for Bids
BID #26-374, Bleachers, Auditorium Seating, and Other Equipment

Other Equipment – Wall Padding (BackStops) for Gyms, Partitions, Curtains, ETC.

Specification Sheet — Gymnasium Wall Padding (Backstops)

1.1 General Summary – Scope

Provide complete wall mounted protective padding for gymnasium walls, end to end walls, and structural elements. Padding shall meet safety standards, and be suitable for K-12 environments, and provide impact attenuation to reduce injury risk.

1.2 Application Codes and Standards

- A. ASTM F2440 — Standard Specification for Indoor Wall/Column Padding
- B. ASTM E84 — Surface Burning Characteristics of Building Materials (Class A or B) California Fire Marshal — flame resistance (if applicable)
- C. Local building and fire codes

1.3 Materials & Construction Requirements

- Minimum 2-inch thick polyurethane or polyethylene foam core (high impact).
- Wood backerboard: 7/16-inch or 1/2-inch OSB or plywood, sealed.
- Vinyl covering: 14–18 oz. per square yard,
- Anti-mildew,
- UV-Resistant.
- All edges wrapped and stapled on rear;
- No exposed fasteners.
- Standard panel widths: 2'—4'; standard heights: 6', 7', 8', or custom.

1.4 Mounting System

- Z Clip or continuous aluminum channel mounting.
- Panels must sit flush with minimal gaps.
- Removable panels for access over electrical/plumbing/doors.
- All hardware concealed; no protruding edges.

1.5 End-Wall Padding Requirements

- Install full coverage end-wall padding behind basketball backstops.
- Include door cutouts, column wraps, and any custom shapes required by site conditions.

1.6 Column & Obstruction Padding

- Provide wrapped padding for exposed beams, columns, and wall protrusions within the play area.

- Padding shall extend a minimum of 6 feet unless otherwise specified.

1.7 Color Options

- Vendor shall provide standard color charts.
- Custom colors or school logos may be requested at additional cost.

1.8 Installation Requirements

- Manufacturer authorized installers only.
- Verify substrate and mounting alignment before installation.
- Ensure panels are level and securely locked into mounting channels.

1.9 Warranty

- Minimum 1 year workmanship warranty.
- Minimum 3 year material/foam/vinyl warranty.

Illustrated Wall Panels and Column Panels _

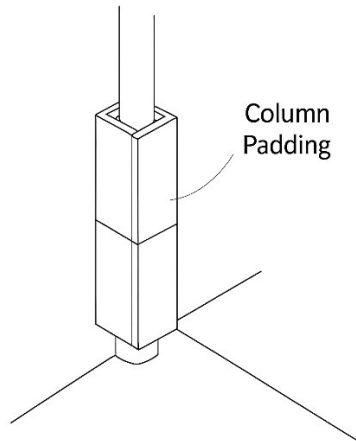
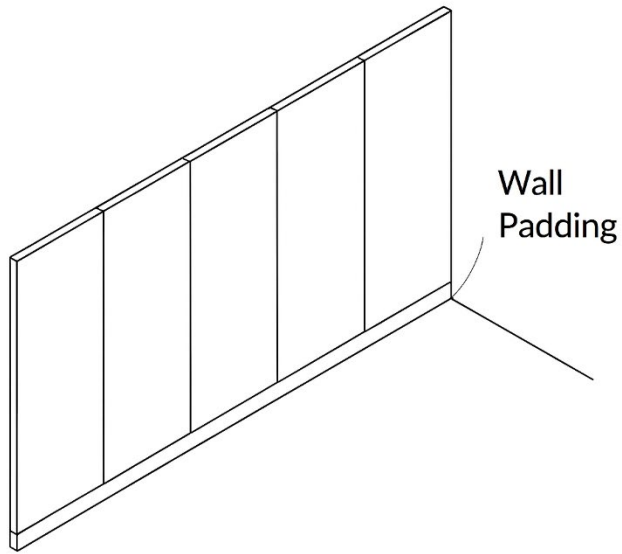

Specification Sheet — Gym Partitions Solid or Movable Partitions Curtains

1. General Requirements

1.1 Scope of Work

Provide all labor, materials, equipment, engineering, and installation required for a complete gymnasium partition system. System shall be new, code-compliant, and designed for long-term, heavy-use performance in a school or community athletic facility.

1.2 System Types

- Solid Gym Partition (Rigid Wall System)
- Movable Partition (Curtain-Style or Folding Partition System)

1.3 Applicable Standards

- ASTM E84 (Surface Burning Characteristics)
- NFPA 701 (Flame Resistance for Fabric Curtain Systems)
- IBC/IRC Building Code Requirements
- ADA accessibility requirements where applicable
- Local seismic and wind-load requirements

1.4 Product Specifications

- A. Solid Gym Partitions (Rigid Wall System)
 - 1) Panel Construction
 - * Solid-core or laminated composite panels
 - * Minimum panel thickness: 1–2 inches
 - * Surface finish: Impact-resistant vinyl, laminate, or painted steel
 - * Standard or custom color options
 - 2) Panel Operation
 - Motorized or manual operation
 - Ceiling-suspended track system
 - Continuous hinge or segmented panel design
 - Integrated safety interlocks
 - 3) Performance
 - Minimum STC rating: 26–33
 - Impact resistance suitable for athletic use
 - Smooth, controlled deployment and retraction
- B. Movable Gym Partitions (Fabric or Vinyl Curtain Systems)
 - 1) Curtain Material
 - Heavy-duty woven polyester or reinforced vinyl
 - Minimum weight: 18–22 oz/sq. yd.
 - Fire-rated per NFPA 701
 - Tear-resistant and mildew-resistant
- C. Operation
 - Motorized winch system with steel cables
 - Optional manual crank operation
 - Vertical-fold, roll-up, or center-stack design
 - Integrated bottom batten for stability
- D. Performance
 - Smooth and quiet operation
 - Reinforced seams
 - Optional mesh or viewing panels

1.5 Structural & Electrical Requirements

- Engineered for ceiling loads, lateral loads, and seismic bracing
- Electrical: 120V or 208/230V, keyed switches, emergency shutoff

1.6 Safety Features

- Safety brake or winch redundancy
- Low-voltage control switches
- Obstruction sensing
- Compliance with building safety standards

1.7 Installation

- Factory-certified installer
- Includes all hardware and supports
- Field measurements required
- Site protection and cleanup included

1.8 Warranty

- Partition system: 5 years
- Motor & control components: 2–5 years
- Labor: 1 year minimum

1.9 Vendor Submittals Information needed For Contract Bid / Proposal

- Product data sheets
- Shop drawings
- Wiring diagrams
- Material samples
- Maintenance manuals
- Installation schedule

Illustration of Movable Gym Partitions – Fold Up or Center Fold

Movable Gym Partitions

Fold-Up Curtain Partition



Center-Fold Partition



Key Components



Motorized Winch



Steel Support Tracks



Bottom Batten



Viewing Mesh Panel
(Optional)



Illustration of Movable Gym Partitions – Curtain Partitions

Curtain Gym Partitions

Vertical Fold Curtain



Roll-Up Curtain



Curtain Partition Features



Motorized Winch



Steel Support Tracks

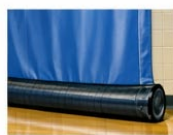

Bottom Batten



Viewing Mesh Panel



(Optional)